

S9407-AB-HBK-010

Conduit Systems for Shipboard Electromagnetic Shielding

RP2120 Conduit end fitting, 45°



90° CONDUIT END FITTING IAW S9407-AB-HBK-010 REV 2, RP2120



How To Order			
Sample Part Number	RP2120	-EM08	-T
Basic Part Number	45° conduit end fitting		
Conduit Part No.	EM02, EM03, EM04, EM05, EM06, EM08, EM10, EM12, EM16, EM20, EM24 (See Material/Finish Note)		
Length Option	T = Telescoping Length S = Short Length		

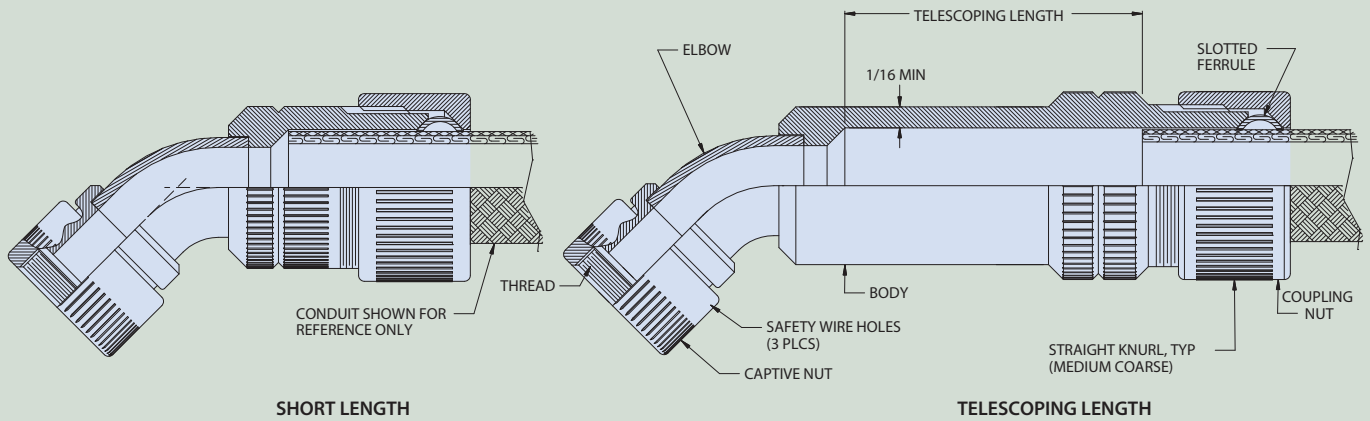

RP2000

MATERIAL / FINISH

Body, Ferrule, Nut - Mild Steel AISI Type B1113 IAW Fed-STD-66 / Electroless Nickel IAW AMS 2404C
For Cadmium/Olive Drab over Electroless Nickel Plating, insert "G" In Place Of "EM" In Part Number
Development. Option "F" Has Been Superseded By "G".