

MISSION-CRITICAL
**INTERCONNECT
SOLUTIONS**



SUBMARINE AND BELOW-DECK

Shipboard EMC Conduit Systems and Fittings

Qualified Components IAW Handbook of Shipboard
Electromagnetic Shielding Practices (S9407-AB-HBK-010)

NOVEMBER 2020



SUBMARINE AND BELOW-DECK

Shipboard EMC Conduit and Fittings

Qualified Components IAW Handbook of Shipboard Electromagnetic Shielding Practice



Glenair is one of the only suppliers of EMC wire protection conduit systems built in accordance with S9407-AB-HBK-010. These ruggedized interconnect fittings, connector adapters, and feed-thrus are utilized in the installation of electrical cables, cableways, and shielding associated with electrical and electronic systems installed aboard submarines, in below-deck areas of surface ships, and in many shore-based installations. The flexible metal-core conduit combined with braze-on and user-installable fittings enhance electromagnetic compatibility (EMC) of shipboard wiring systems. Electromagnetic Compatibility (EMC) is a major consideration during ship design and equipment installation because without EMC the warfare capacity of Navy ships is seriously reduced.

This catalog is intended for use by ship designers, work planners, and personnel engaged in the installation of electrical and electronic cables and equipment for new ship construction, SHIPALT installation and repair at shipyards, tenders and other activities.

- US Navy-qualified conduit fittings and flexible metal-core conduit
- GR2000 braze-on type feed-thrus, transitions, and bulkhead penetrators
- RP2000 conduit fittings and adapters designed for on-site termination and assembly
- Qualified grounding clamps and ground straps IAW M24749

S9407-AB-HBK-010
Conduit Systems for Shipboard Electromagnetic Shielding
 Product Selection Guide



	<p>GR2000 Series Fittings Fittings, couplers, and adapters for shipboard conduit systems, Braze-on type</p> <p style="text-align: right;">page 4</p>	GR2000
	<p>RP2000 Series Fittings Fittings, couplers, and adapters for shipboard conduit systems. Reusable type.</p> <p style="text-align: right;">page 15</p>	RP2000
	<p>Flexible Metal-Core Conduit Type 1 with braided shielding, Type 2 with shield and rubber jacket</p> <p style="text-align: right;">page 38</p>	METAL-CORE CONDUIT
	<p>Grounding Clamp and Grounding Straps Grounding clamp with lug for shipboard conduit, M24749 qualified ground straps</p> <p style="text-align: right;">page 42</p>	GROUNDING CLAMPS AND STRAPS
	<p>AutoShrink cold-shrink tubing, Piggyback Boot Adapters, ProSeal protective covers, and other wire protection technologies</p> <p>Showcase of QPL and Glenair Signature technologies for wire protection, electromagnetic shielding and more.</p> <p style="text-align: right;">page 44</p>	WIRE PROTECTION

Conduit Systems for Shipboard Electromagnetic Shielding

GR2000- and RP2000- Conduit fittings, Navy qualification letter



Conduit Systems for Shipboard Electromagnetic Shielding

Flexible Shielding Conduit, Navy qualification letter

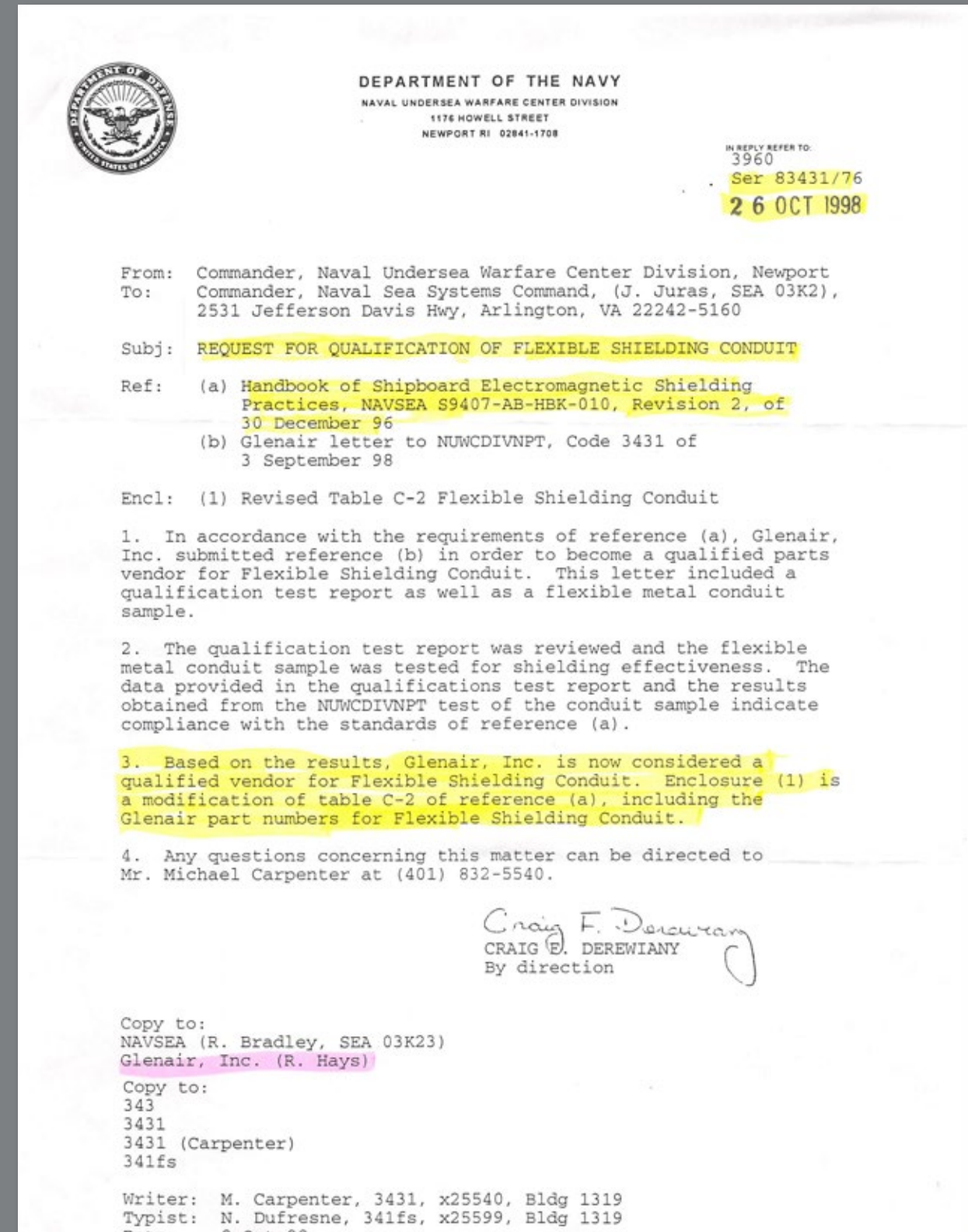
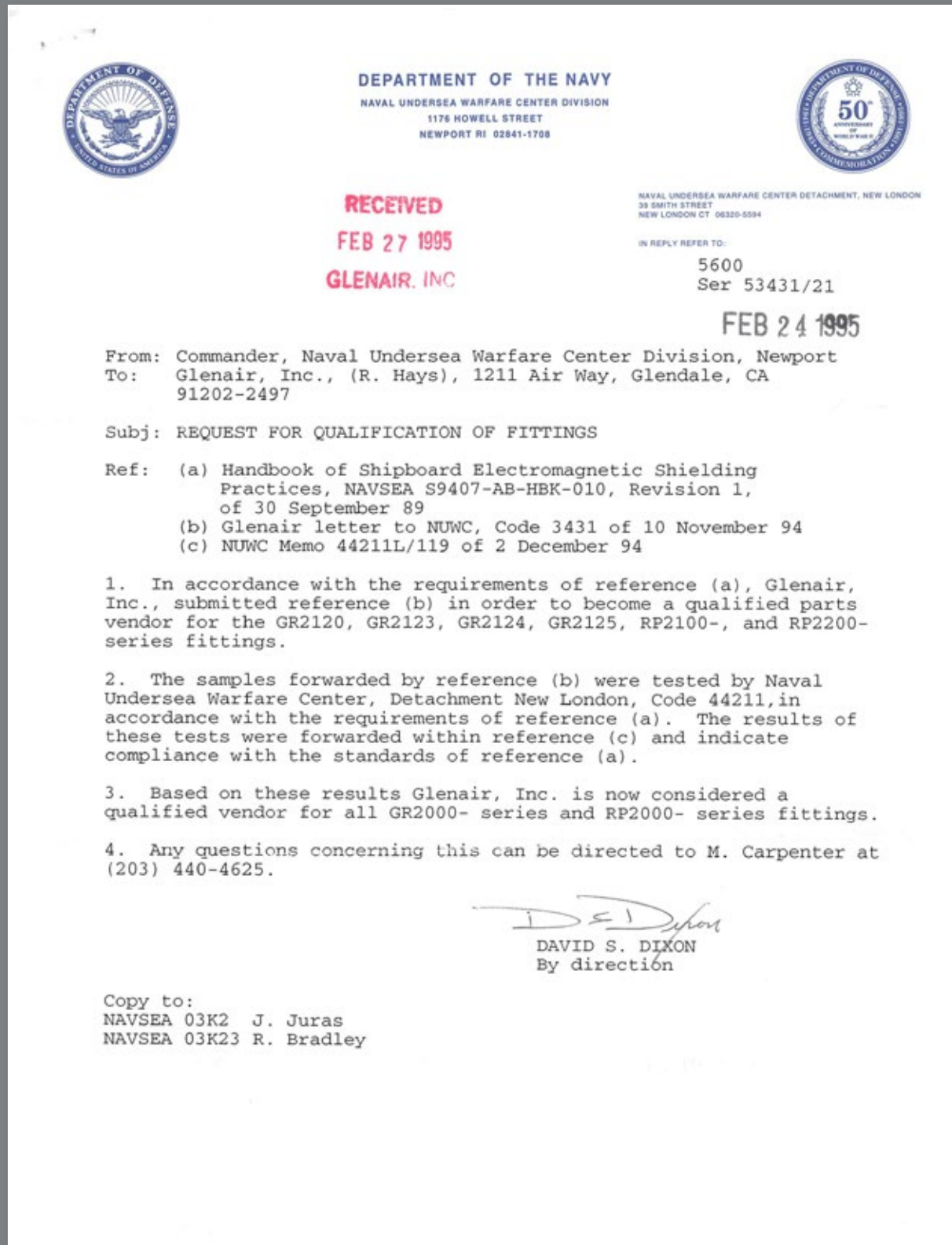

S9407-AB-HBK-010
**Conduit Systems for Shipboard
 Electromagnetic Shielding**
 GR2120 Transition Fitting



S9407-AB-HBK-010
**Conduit Systems for Shipboard
 Electromagnetic Shielding**
 GR2121 Enclosure Fitting

TRANSITION FITTING FOR MIL-DTL-5015 CONNECTORS IAW S9407-AB-HBK-010 REV 2, GR2120



How To Order						
Sample Part Number	GR2120	-M	-12	-EM08	-2.5	SN
Basic Part Number	Conduit Fitting for M5015 connectors					
Connector Symbol	Symbol	Mfr.	Class	Description		
	H	Amphenol	A	MS3100, MS3101, MS3106, 97-3100, 97-3101, 97-3106		
	J	Amphenol	E, R	MS3100, MS3101, MS3106, 69-3100, 69-3101, 69-3106		
	L	Bendix	A, E, R	MS3100, MS3101, MS3106, 10-214, 10-720, 10-726		
	M	Cannon	A	MS3100, MS3101, MS3106		
N	Cannon	E, R	MS3100, MS3101, MS3106, (CA01, CA06)			
Connector Shell Size	8S, 8, 10S, 10SL, 12S, 14S, 16S, 12, 14, 16, 18, 20, 22, 24, 28, 32, 36, 40, 44, 48. See sales drawing for specifics					
Conduit Part No.	EM02, EM03, EM04, EM05, EM06, EM08, EM10, EM12, EM16, EM20, EM24. See sales drawing for full dimensional details..					
Body / Adapter Length	In inches. Std. min. length = 2" (one-piece/style A); 2.5" (two-piece/style B)					
Material / Finish	SN = mild steel with cadmium over electroless nickel finish Omit = mild steel with electroless nickel finish IAW AMS 2404C					

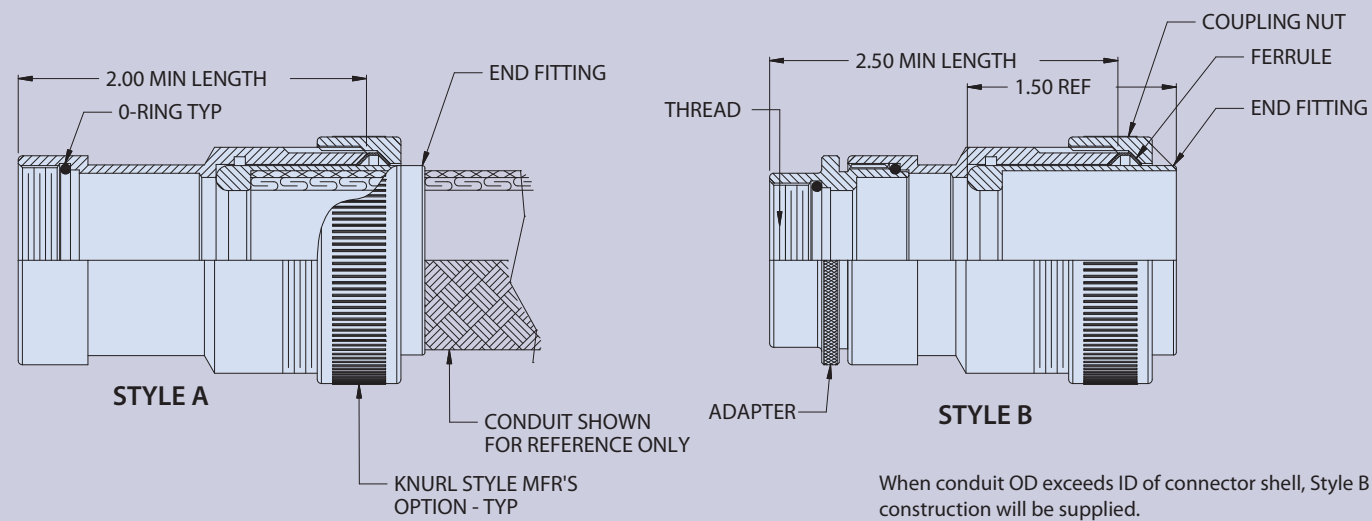

MATERIAL / FINISH

Adapter, Body, Ferrule, Nut - Mild Steel AISI Type B1113 IAW Fed-STD-66
 End Fitting - 300 Series SST / Passivated
 O-Ring - Nitrile/Buna-N

ENCLOSURE FITTING FOR MIL-DTL-5015 CONNECTORS IAW S9407-AB-HBK-010 REV 2, GR2121

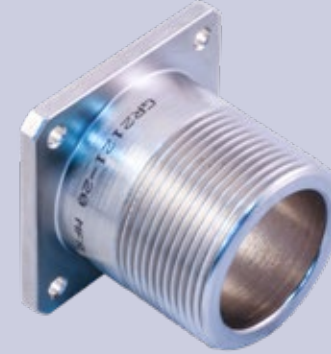

How To Order			
Sample Part Number	GR2121	-28	SN
Basic Part Number	Enclosure Fitting for M5015 connectors		
Connector Shell Size	8S, 10S, 10SL, 12S, 14S, 16S, 18, 20, 22, 24, 28, 32, 36, 40, 44, 48. See sales drawing for full dimensional details..		
Material / Finish	SN = mild steel with cadmium over electroless nickel finish SM = mild steel with electroless nickel finish IAW AMS 2404C (Finish symbol "no suffix" is for legacy parts, superseded by "SM")		

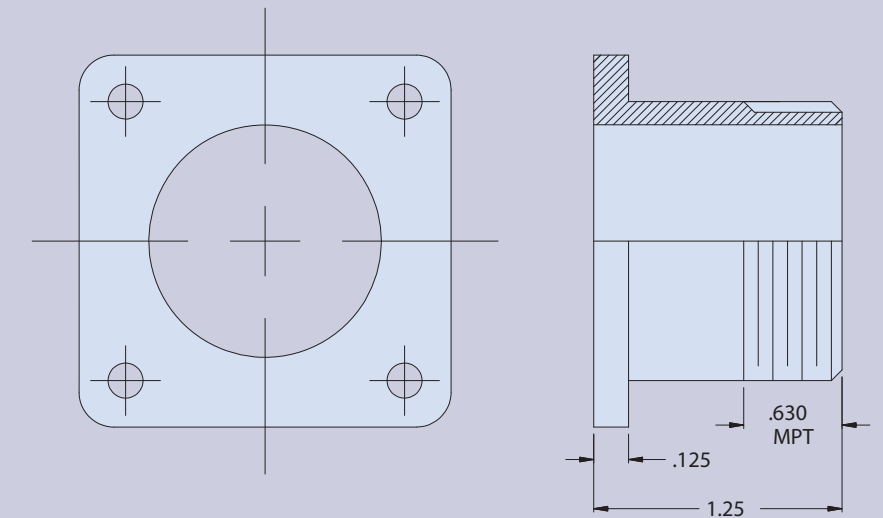

MATERIAL / FINISH

Mild Steel AISI Type B1113 IAW Fed-STD-66

S9407-AB-HBK-010 Conduit Systems for Shipboard Electromagnetic Shielding



GR2122 90° Elbow adapter to M5015 connector

90° ELBOW, NON-ENVIRONMENTAL FOR MIL-DTL-5015 CONNECTORS IAW S9407-AB-HBK-010 REV 2, GR2122



How To Order			
Sample Part Number	GR2122	-101	SN
Basic Part Number	Conduit Fitting for M5015 connectors		
Part Number / Shell Size	See table below. See sales drawing for full dimensional details.		
Material / Finish	SN = mild steel with cadmium over electroless nickel finish SM = mild steel with electroless nickel finish IAW AMS 2404C (Finish symbol "no suffix" is for legacy parts, superseded by "SM")		

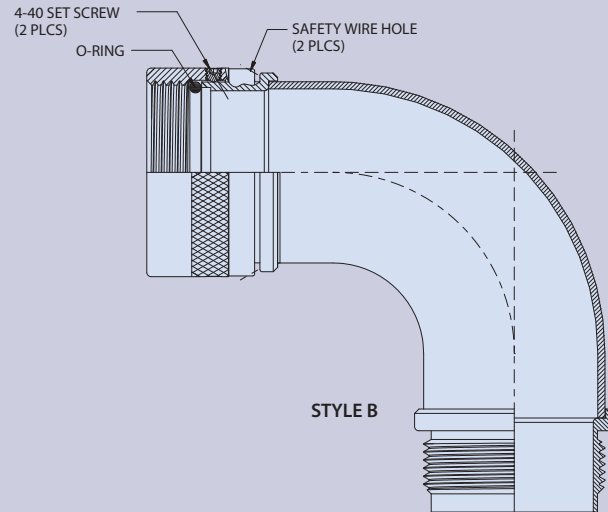
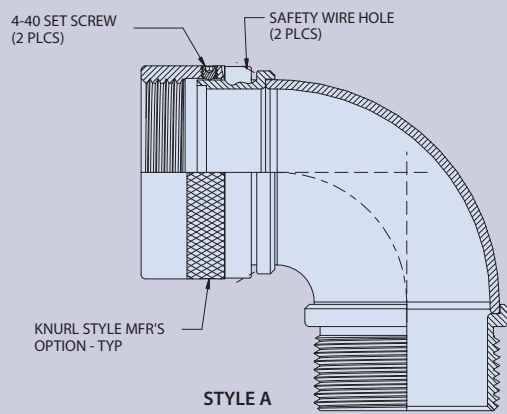

Part No.	Shell Size	Part No.	Shell Size
GR2122-101	10S	GR2122-242	24
GR2122-121	12S	GR2122-281	28
GR2122-131	12	GR2122-282	28
GR2122-141	14S	GR2122-321	32
GR2122-151	14	GR2122-322	32
GR2122-161	16S	GR2122-361	36
GR2122-171	16	GR2122-362	36
GR2122-181	18	GR2122-401	40
GR2122-201	20	GR2122-402	40
GR2122-202	20	GR2122-441	44
GR2122-221	22	GR2122-481	48
GR2122-222	22	GR2122-482	48
GR2122-241	24		

Part No.	Shell Size	Conn. Sym.	Part No.	Shell Size	Conn. Sym.
GR2122-081E	8S	L	GR2122-203E	20	J
GR2122-082E	8S	H	GR2122-201E	20	HLMN
GR2122-083E	8S	JMN	GR2122-221E	22	HJLMN
GR2122-101E	10S	HJLN	GR2122-241E	24	HJLMN
GR2122-102E	10S	M	GR2122-281E	28	HJLMN
GR2122-103E	10SL	MN	GR2122-321E	32	LMN
GR2122-104E	10SL	HJL	GR2122-323E	32	HJ
GR2122-121E	12S	LN	GR2122-361E	36	L
GR2122-122E	12S	HJM	GR2122-363E	36	J
GR2122-123E	12SL	H	GR2122-364E	36	MN
GR2122-141E	14S	HJLMN	GR2122-365E	36	H
GR2122-161E	16S	HJLMN	GR2122-403E	40	L
GR2122-132E	12	LN	GR2122-404E	40	HMN
GR2122-133E	12	NM	GR2122-442E	44	HN
GR2122-151E	14	HLMN	GR2122-483E	48	N
GR2122-171E	16	HJLMN	GR2122-484E	48	H
GR2122-181E	18	HJLMN			

MATERIAL / FINISH

Adapter, Elbow, and Coupling Nut - Mild Steel AISI Type B1113 IAW Fed-STD-66
Hardware CRES / passivate • O-Ring - Nitrile / Buna N

NOTE

Amphenol, Bendix, and Cannon "A" Class connectors, and Shell Size "10SL" of Cannon "E" and "R" class connectors should not be selected for environmental assemblies

S9407-AB-HBK-010 Conduit Systems for Shipboard Electromagnetic Shielding

GR2123 Transition Fitting



TRANSITION FITTING FOR BULKHEAD STUFFING TUBE IAW S9407-AB-HBK-010 REV 2, GR2123

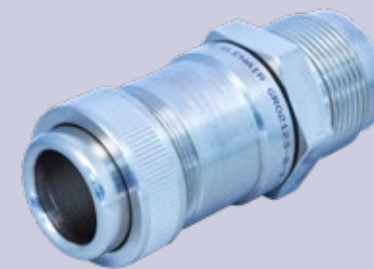

How To Order					
Sample Part Number	GR2123	-2	-3.5	-EM04	SN
Basic Part Number	Transition fitting for bulkhead stuffing tube				
Dash No.	1, 2, 3, 3, 4, 5, 6, 7, 8, 9, 10, 11, 12, 13, 14, 15, 16, 17, 18, 19. See sales drawing for full dimensional details.				
Body / Adapter Length	In inches. Std. min. length = 3" (one-piece/style A); 3.5" (two-piece/style B)				
Conduit Part No.	EM02, EM03, EM04, EM05, EM06, EM08, EM10, EM12, EM16, EM20, EM24				
Material / Finish	SN = mild steel with cadmium over electroless nickel finish Omit = mild steel with electroless nickel finish IAW AMS 2404C				

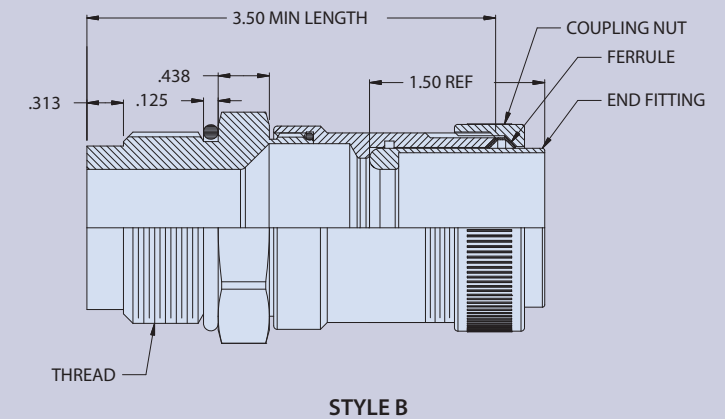
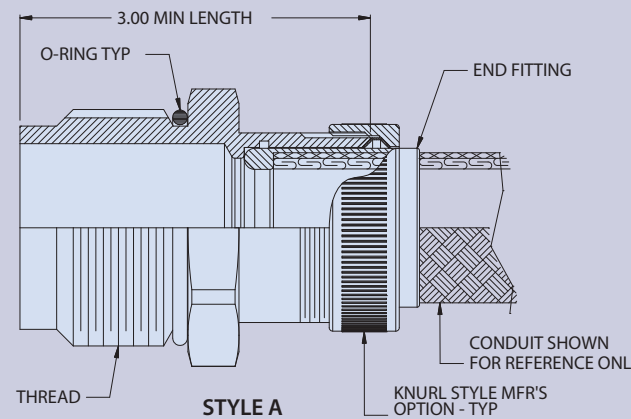

MATERIAL / FINISH

Adapter, Body, Ferrule, Nut - Mild Steel AISI Type B1113 IAW Fed-STD-66
End Fitting - 300 Series SST / Passivated
O-Ring - Nitrile/Buna-N

GR2000

S9407-AB-HBK-010
**Conduit Systems for Shipboard
 Electromagnetic Shielding**
 GR2124 Transition Fitting



S9407-AB-HBK-010
**Conduit Systems for Shipboard
 Electromagnetic Shielding**
 GR2125 Transition Fitting



TRANSITION FITTING FOR MS SERIES BACKSHELL IAW S9407-AB-HBK-010 REV 2, GR2124

How To Order						
Sample Part Number		GR2124	-3	-EM08	-2.5	SN
Basic Part Number	Transition fitting for MS series backshell					
Dash No.	3, 4, 6, 8, 10, 12, 16, 20, 24, 28, 32, 40. See sales drawing for full dimensional details.					
Conduit Part No.	EM02, EM03, EM04, EM05, EM06, EM08, EM10, EM12, EM16, EM20, EM24					
Body / Adapter Length	In inches. Std. min. length = 2" (one-piece/style A); 2.5" (two-piece/style B)					
Material / Finish	SN = mild steel with cadmium over electroless nickel finish Omit = mild steel with electroless nickel finish IAW AMS 2404C					

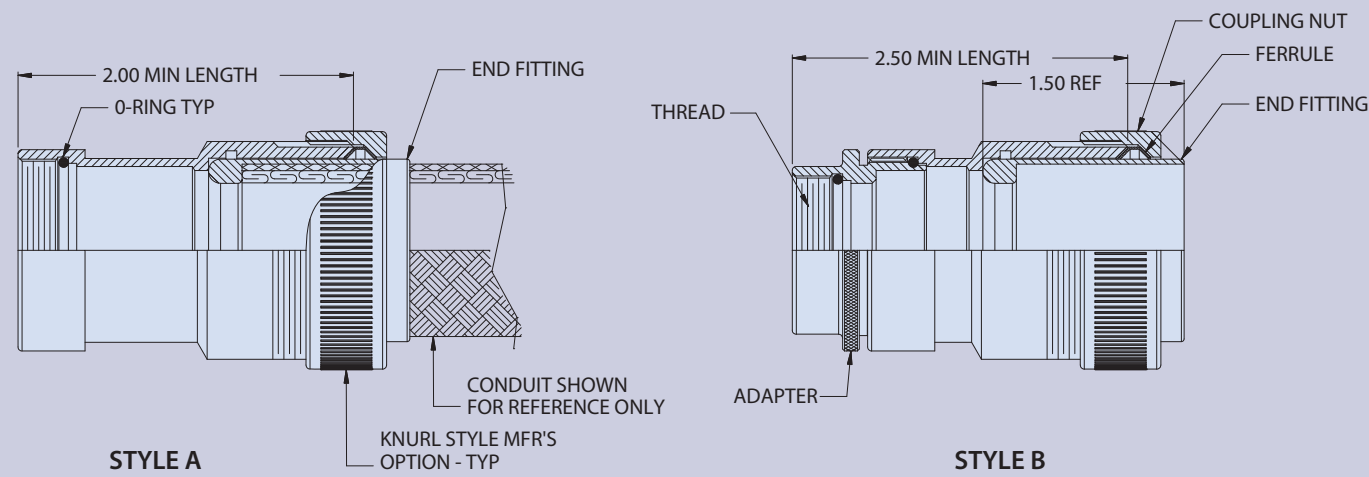

MATERIAL / FINISH

Adaper, Body, Ferrule, Nut - Mild Steel AISI Type B1113 IAW Fed-STD-66
 End Fitting - 300 Series SST / Passivated
 O-Ring - Nitrile/Buna-N

TRANSITION FITTING FOR TRIAXIAL CONNECTOR IAW S9407-AB-HBK-010 REV 2, GR2125

How To Order						
Sample Part Number		GR2125	-4	-EM02	-2.5	SN
Basic Part Number	Transition fitting for Triaxial connector					
Dash No.	4, 5, 6, 7. See sales drawing for full dimensional details.					
Conduit Part No.	EM02, EM03, EM04, EM05, EM06, EM08, EM10, EM12, EM16, EM20, EM24					
Body / Adapter Length	In inches. Std. min. length = 2" (one-piece/style A); 2.5" (two-piece/style B)					
Material / Finish	SN = mild steel with cadmium over electroless nickel finish Omit = mild steel with electroless nickel finish IAW AMS 2404C					

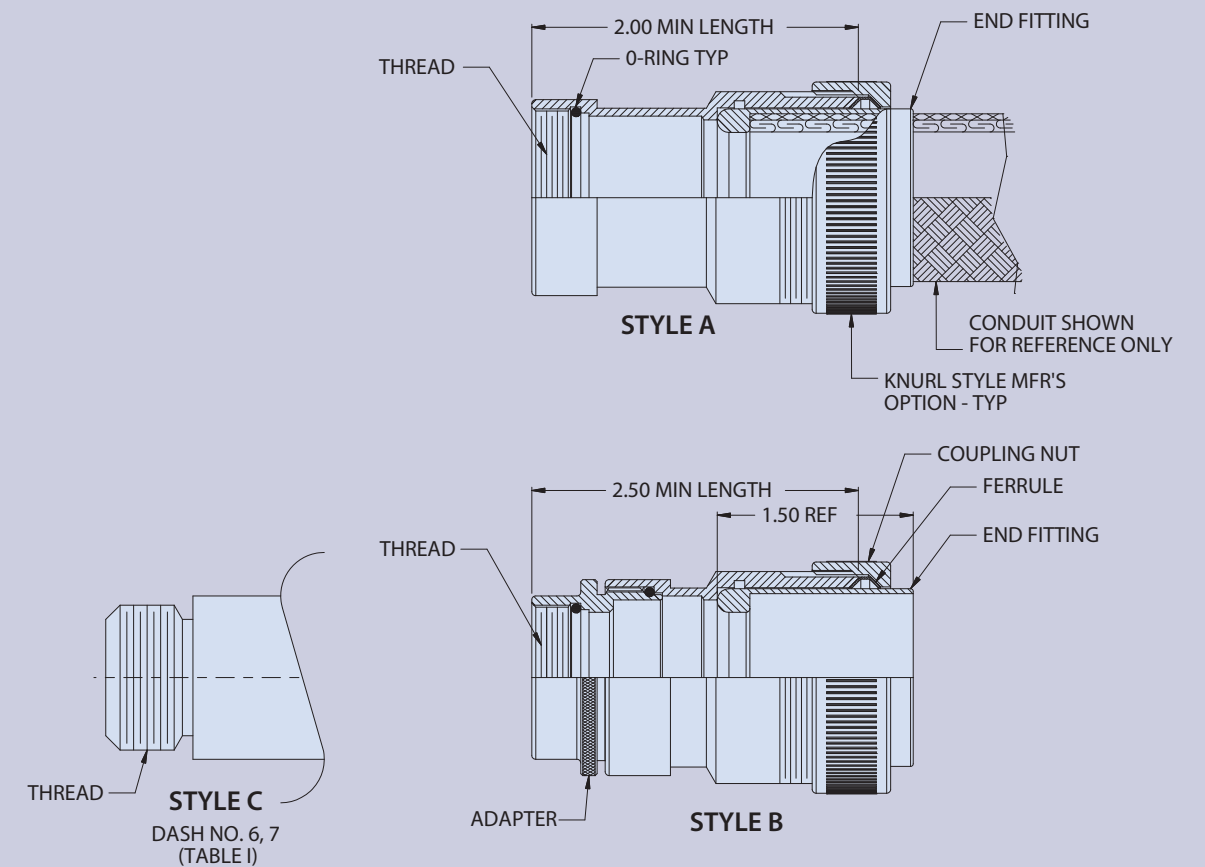

MATERIAL / FINISH

Adaper, Body, Ferrule, Nut - Mild Steel AISI Type B1113 IAW Fed-STD-66
 End Fitting - 300 Series SST / Passivated
 O-Ring - Nitrile/Buna-N

S9407-AB-HBK-010
**Conduit Systems for Shipboard
 Electromagnetic Shielding**
 GR2126 End fitting



S9407-AB-HBK-010
**Conduit Systems for Shipboard
 Electromagnetic Shielding**
 GR2127 Conduit coupling

END FITTING FOR FLEXIBLE CONDUIT IAW S9407-AB-HBK-010 REV 2, GR2126

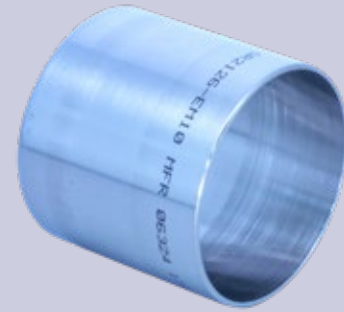

How To Order		
Sample Part Number	GR2126	-EM08
Basic Part Number	End fitting	
Conduit Part No.	EM02, EM03, EM04, EM05, EM06, EM08, EM10, EM12, EM16, EM20, EM24	

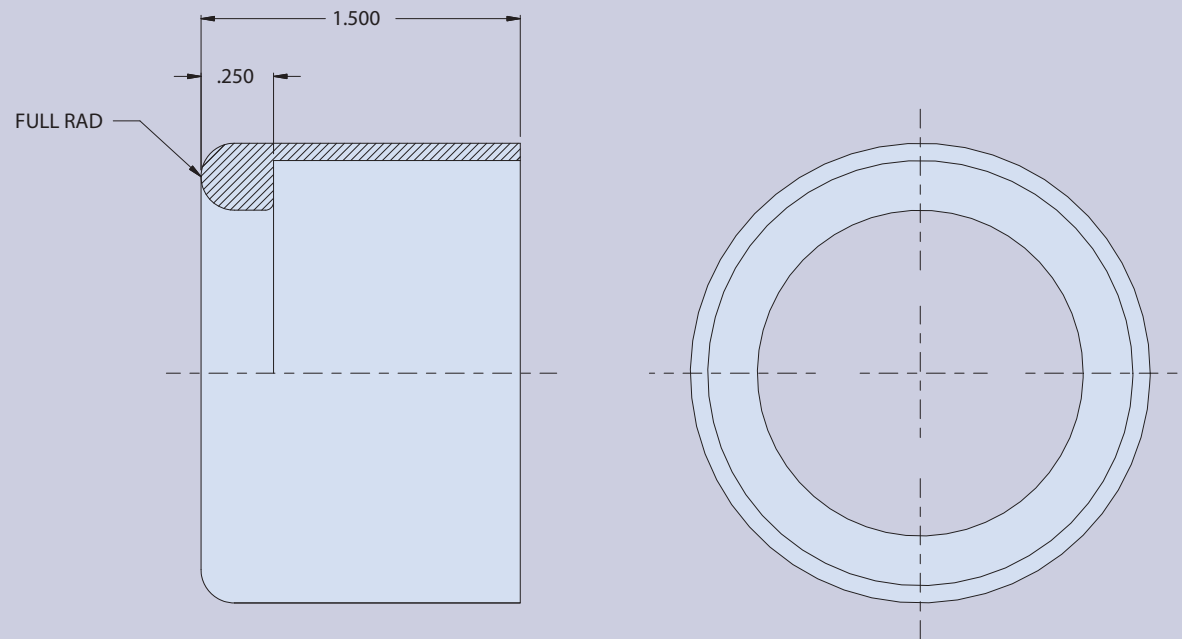

CONDUIT COUPLING IAW S9407-AB-HBK-010 REV 2, GR2127

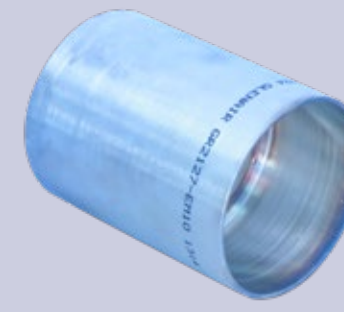

How To Order		
Sample Part Number	GR2127	-EM08
Basic Part Number	Conduit coupling	
Conduit Part No.	EM02, EM03, EM04, EM05, EM06, EM08, EM10, EM12, EM16, EM20, EM24	

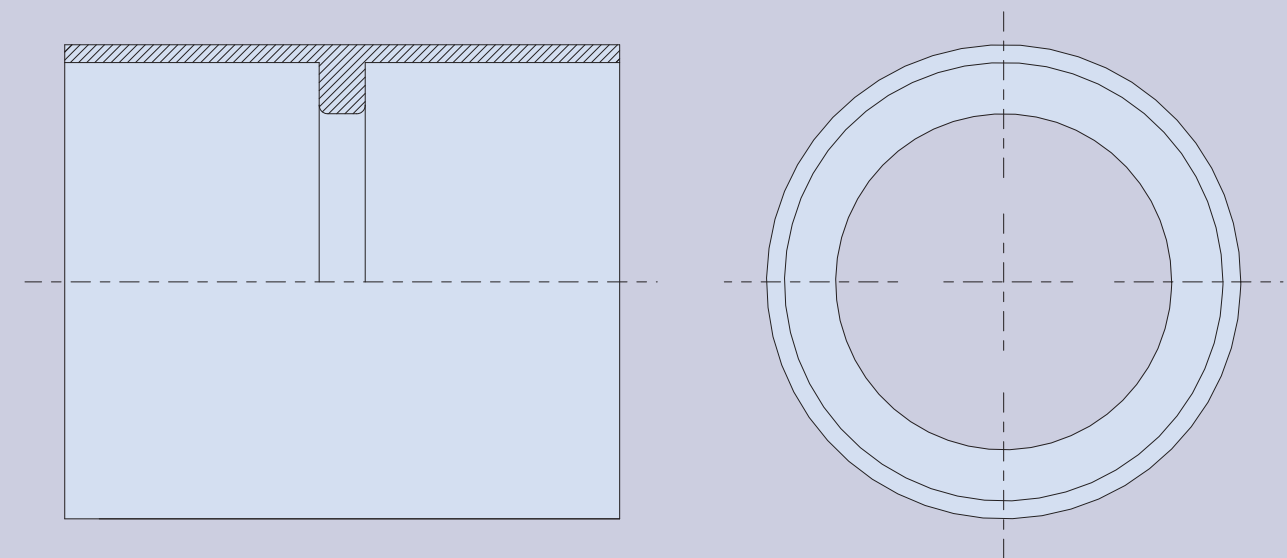

MATERIAL / FINISH

End Fitting - 300 Series SST / Passivated IAW QQ-S-763/PASSIVATED IAW QQ-P-35

MATERIAL / FINISH

Mild Carbon Steel AISI Type B1113 IAW FED-STD-66 / Cadmium IAW QQ-P-416, Type I, Class 3.

GR2000

GR2000

S9407-AB-HBK-010
**Conduit Systems for Shipboard
 Electromagnetic Shielding**
 GR2128 Panel fitting



S9407-AB-HBK-010
**Conduit Systems for Shipboard
 Electromagnetic Shielding**
 GR2129 Ferrule and coupling nut

PANEL FITTING FOR FLEXIBLE CONDUIT IAW S9407-AB-HBK-010 REV 2, GR2128

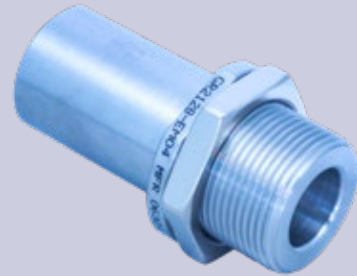

How To Order		
Sample Part Number	GR2128	-EM08
Basic Part Number	Panel fitting	
Conduit Part No.	EM02, EM03, EM04, EM05, EM06, EM08, EM10, EM12, EM16, EM20, EM24	

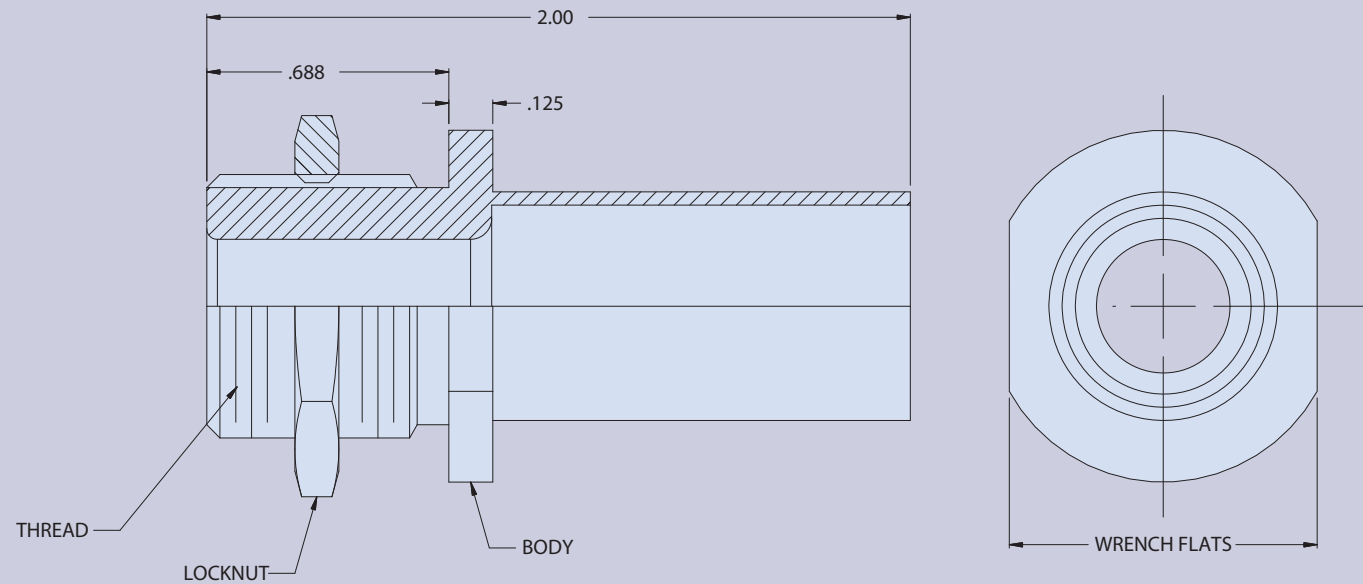

MATERIAL / FINISH

Body - 300 Series SST / Passivated
 Locknut - Mild Carbon Steel AISI Type B1113 IAW Fed-STD-66 / Electroless nickel IAW AMS 2404C

FERRULE AND COUPLING NUT FOR FLEXIBLE CONDUIT IAW S9407-AB-HBK-010 REV 2, GR2129

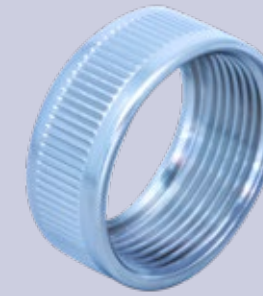

How To Order		
Sample Part Number	GR2129	-EM08
Basic Part Number	Ferrule and coupling nut	
Conduit Part No.	EM02, EM03, EM04, EM05, EM06, EM08, EM10, EM12, EM16, EM20, EM24	

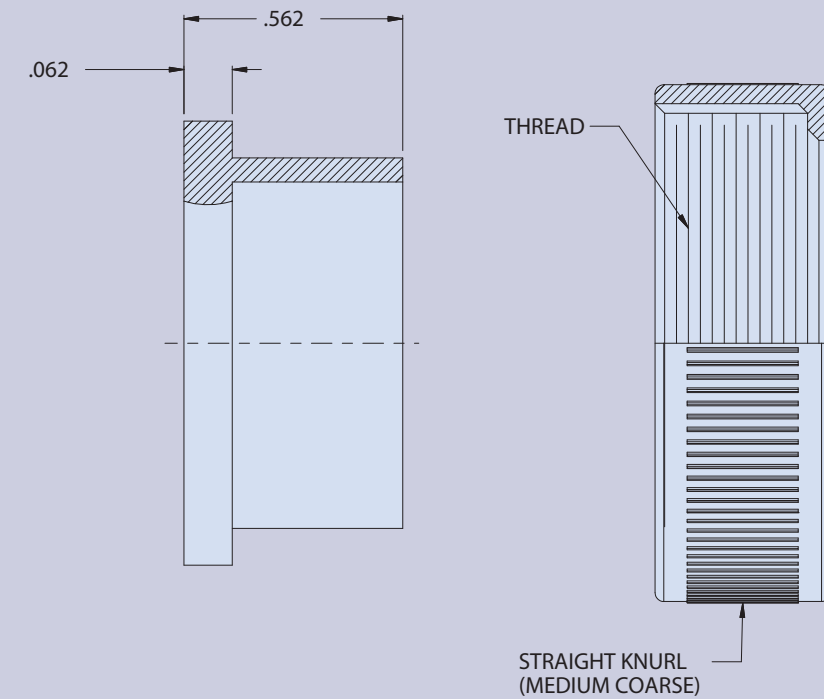

NOTE

EM06 Assembly couples 3/4-Inch conduit to the Stuffing Tube Adapter, MX-7637/U.

MATERIAL / FINISH

Ferrule - 300 Series SST / Passivated
 Coupling Nut - Mild Carbon Steel AISI Type B1113 IAW Fed-STD-66 / Electroless nickel IAW AMS 2404C

S9407-AB-HBK-010
**Conduit Systems for Shipboard
 Electromagnetic Shielding**
 GR2130 Isolator adapter



S9407-AB-HBK-010
**Conduit Systems for Shipboard
 Electromagnetic Shielding**
 RP2100 Conduit end fitting, straight

GR2000

ISOLATOR ADAPTER IAW S9407-AB-HBK-010 REV 2, GR2130

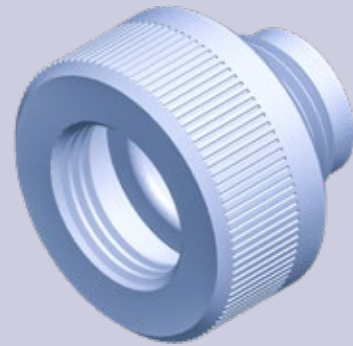

How To Order				
Sample Part Number	GR2130	-05	-N	-10SL
Basic Part Number	Isolator adapter			
Thread Size	01 - 55. See sales drawing for full details.			
Material	N - Nylon STN - Super Tough Nylon			
Connector Shell Size	8S, 8, 10S, 10SL, 12S, 14S, 16S, 12, 14, 16, 18, 20, 22, 24, 28, 32, 36, 40, 44, 48. See sales drawing GR2120 for specifics			

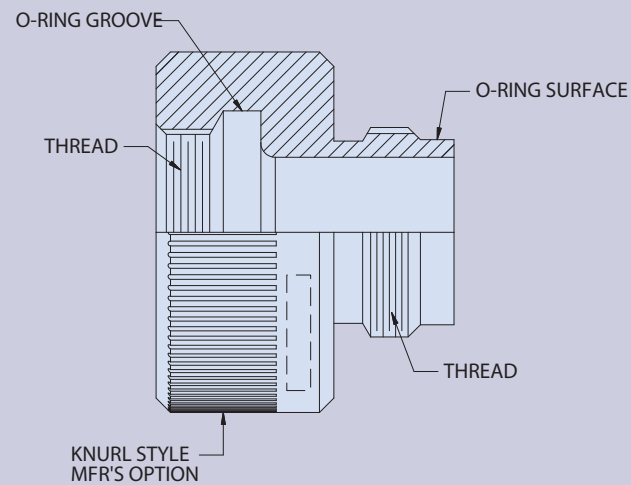

MATERIAL / FINISH

Adapter - Nylon / None

STRAIGHT CONDUIT END FITTING IAW S9407-AB-HBK-010 REV 2, RP2100



RP2100-G Cadmium / Olive Drab finish option

How To Order			
Sample Part Number	RP2100	-EM08	-T
Basic Part Number	Straight conduit end fitting		
Conduit Part No.	EM02, EM03, EM04, EM05, EM06, EM08, EM10, EM12, EM16, EM20, EM24 (See Material/Finish Note)		
Length Option	T = Telescoping Length S = Short Length		

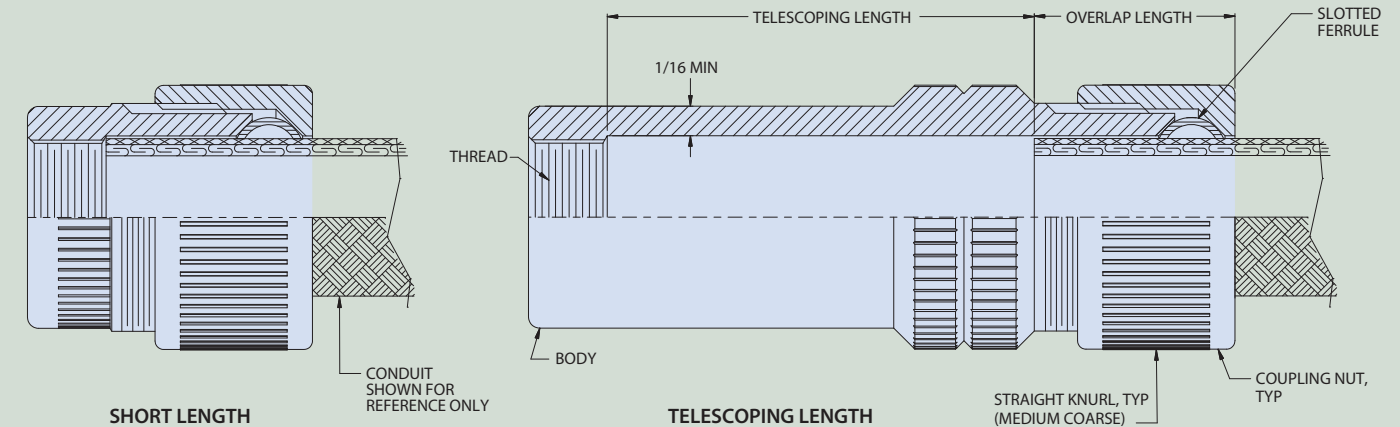

MATERIAL / FINISH

Body, Ferrule, Nut - Mild Steel AISI Type B1113 IAW Fed-STD-66 / Electroless Nickel IAW AMS 2404C
 For Cadmium/Olive Drab over Electroless Nickel Plating, insert "G" In Place Of "EM" In Part Number
 Development. Option "F" Has Been Superseded By "G".

RP2000

S9407-AB-HBK-010
**Conduit Systems for Shipboard
 Electromagnetic Shielding**
 RP2110 Conduit end fitting, 90°



S9407-AB-HBK-010
**Conduit Systems for Shipboard
 Electromagnetic Shielding**
 RP2120 Conduit end fitting, 45°



90° CONDUIT END FITTING IAW S9407-AB-HBK-010 REV 2, RP2110

How To Order			
Sample Part Number	RP2110	-EM08	-T
Basic Part Number	90 conduit° end fitting		
Conduit Part No.	EM02, EM03, EM04, EM05, EM06, EM08, EM10, EM12, EM16, EM20, EM24 (See Material/Finish Note)		
Length Option	T = Telescoping Length S = Short Length		

90° CONDUIT END FITTING IAW S9407-AB-HBK-010 REV 2, RP2120

How To Order			
Sample Part Number	RP2120	-EM08	-T
Basic Part Number	45° conduit end fitting		
Conduit Part No.	EM02, EM03, EM04, EM05, EM06, EM08, EM10, EM12, EM16, EM20, EM24 (See Material/Finish Note)		
Length Option	T = Telescoping Length S = Short Length		



RP2000

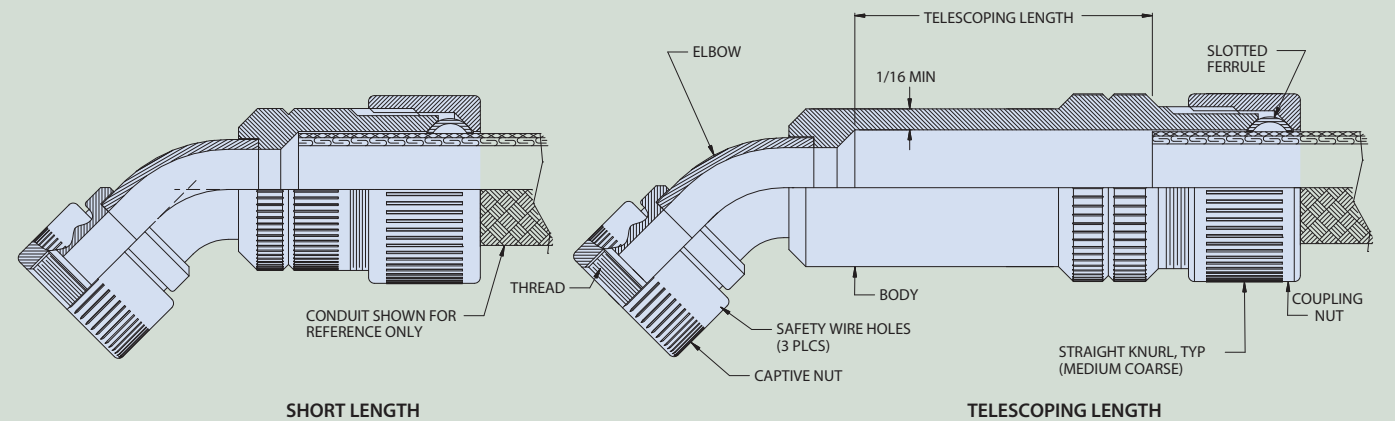
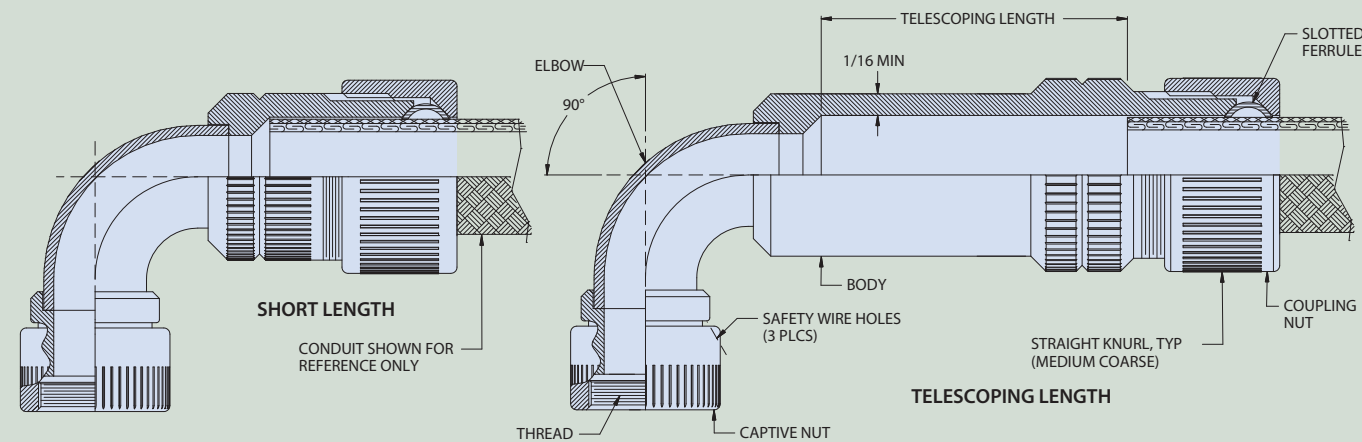

RP2000

MATERIAL / FINISH

Body, Ferrule, Nut - Mild Steel AISI Type B1113 IAW Fed-STD-66 / Electroless Nickel IAW AMS 2404C
 For Cadmium/Olive Drab over Electroless Nickel Plating, insert "G" In Place Of "EM" In Part Number Development. Option "F" Has Been Superseded By "G".

MATERIAL / FINISH

Body, Ferrule, Nut - Mild Steel AISI Type B1113 IAW Fed-STD-66 / Electroless Nickel IAW AMS 2404C
 For Cadmium/Olive Drab over Electroless Nickel Plating, insert "G" In Place Of "EM" In Part Number Development. Option "F" Has Been Superseded By "G".

S9407-AB-HBK-010
**Conduit Systems for Shipboard
 Electromagnetic Shielding**

RP2130 End fitting, conduit-to-panel



S9407-AB-HBK-010
**Conduit Systems for Shipboard
 Electromagnetic Shielding**

RP2140 End fitting, conduit-to-pipe thread (tapered)



CONDUIT END FITTING IAW S9407-AB-HBK-010 REV 2, RP2130

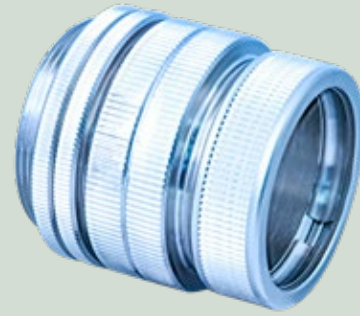

How To Order		
Sample Part Number	RP2130	-EM08
Basic Part Number	Panel fitting	
Conduit Part No.	EM02, EM03, EM04, EM05, EM06, EM08, EM10, EM12, EM16, EM20, EM24 (See Material/Finish Note)	

RP2000

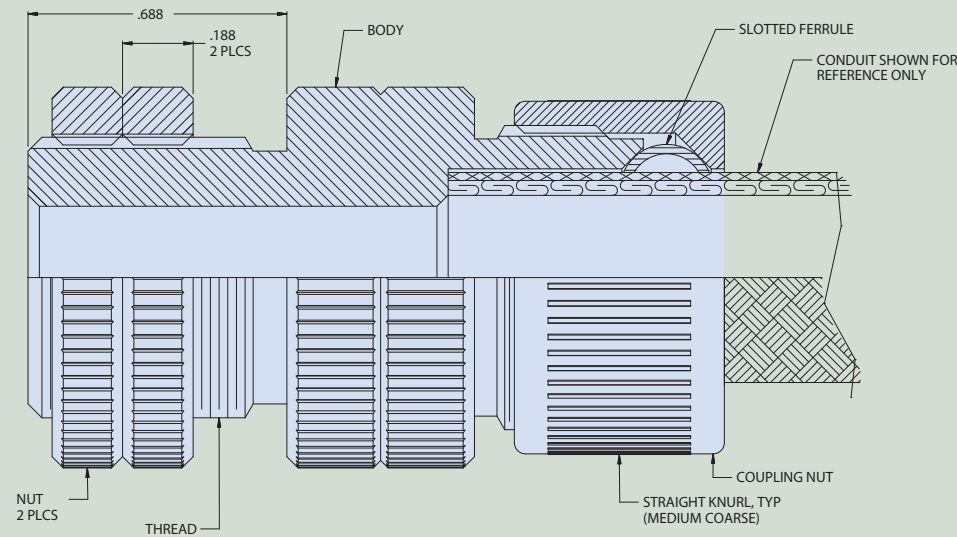

MATERIAL / FINISH

Body, Ferrule, Nut - Mild Steel AISI Type B1113 IAW Fed-STD-66 / Electroless Nickel IAW AMS 2404C
 For Cadmium/Olive Drab over Electroless Nickel Plating, insert "G" In Place Of "EM" In Part Number Development. Option "F" Has Been Superseded By "G".

CONDUIT TO PIPE THREAD TAPERED END FITTING IAW S9407-AB-HBK-010 REV 2, RP2140

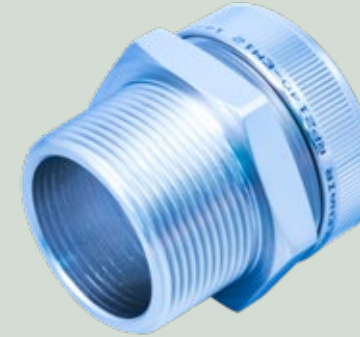

How To Order		
Sample Part Number	RP2140	-EM08
Basic Part Number	End fitting	
Conduit Part No.	EM02, EM03, EM04, EM05, EM06, EM08, EM10, EM12, EM16, EM20, EM24 (See Material/Finish Note)	

RP2000

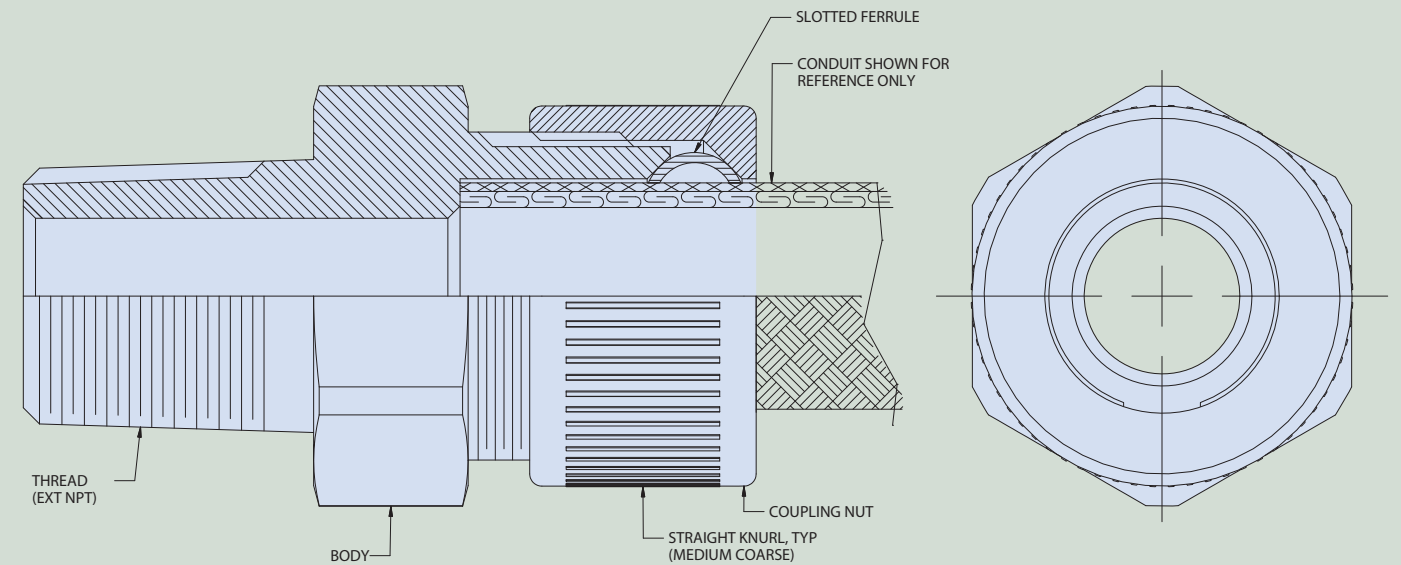

MATERIAL / FINISH

Body, Ferrule, Nut - Mild Steel AISI Type B1113 IAW Fed-STD-66 / Electroless Nickel IAW AMS 2404C
 For Cadmium/Olive Drab over Electroless Nickel Plating, insert "G" In Place Of "EM" In Part Number Development. Option "F" Has Been Superseded By "G".



CONDUIT END FITTING IAW S9407-AB-HBK-010 REV 2, RP2141

How To Order		
Sample Part Number	RP2141	-EM08
Basic Part Number	End fitting	
Conduit Part No.	EM02, EM03, EM04, EM05, EM06, EM08, EM10, EM12, EM16, EM20, EM24 (See Material/Finish Note)	

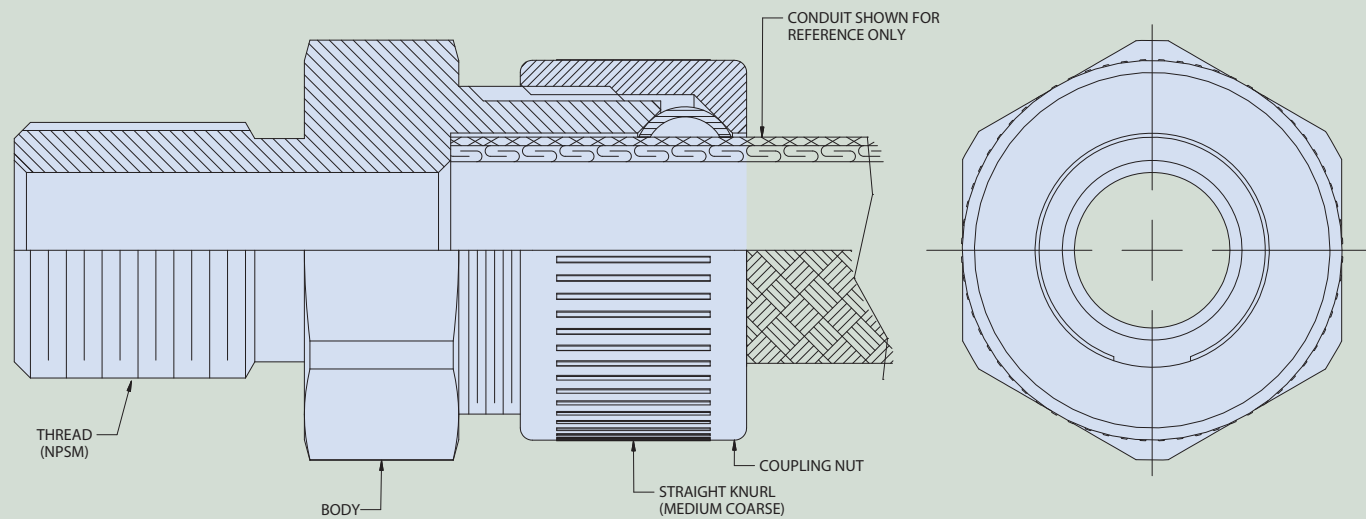

CONDUIT-TO-CONDUIT COUPLING IAW S9407-AB-HBK-010 REV 2, RP2200

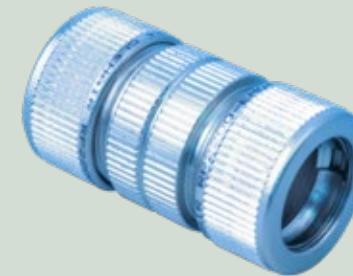

How To Order			
Sample Part Number	RP2200	-EM08	-10
Basic Part Number	Conduit-to-conduit coupling		
Conduit Part No.	EM02, EM03, EM04, EM05, EM06, EM08, EM10, EM12, EM16, EM20, EM24 (See Material/Finish Note)		
Large Conduit Part No.	EM02, EM03, EM04, EM05, EM06, EM08, EM10, EM12, EM16, EM20, EM24 Omit for Style I (See Material/Finish Note)		

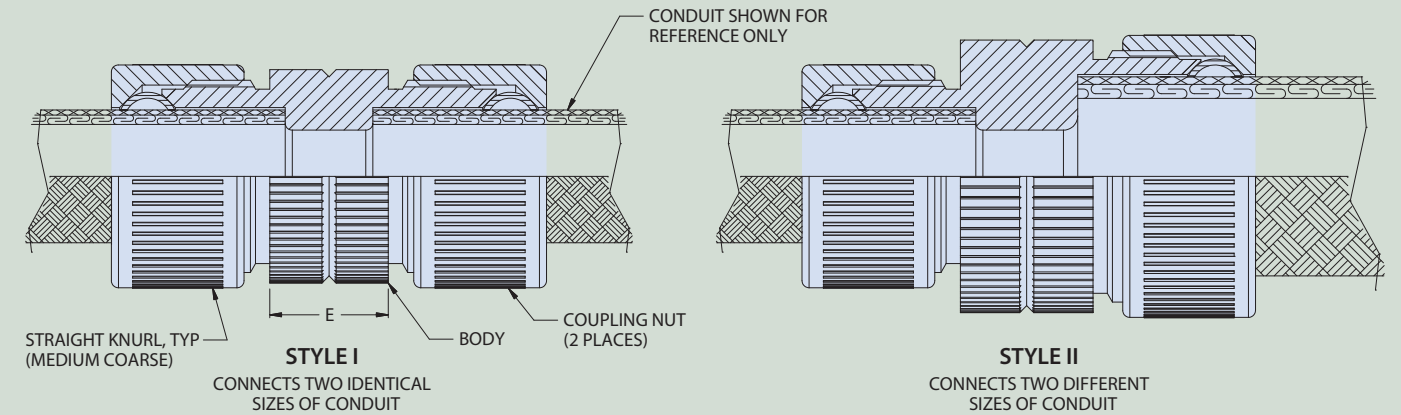

MATERIAL / FINISH

Body, Ferrule, Nut - Mild Steel AISI Type B1113 IAW Fed-STD-66 / Electroless Nickel IAW AMS 2404C
For Cadmium/Olive Drab over Electroless Nickel Plating, insert "G" In Place Of "EM" In Part Number Development. Option "F" Has Been Superseded By "G".

MATERIAL / FINISH

Body, Ferrule, Nut - Mild Steel AISI Type B1113 IAW Fed-STD-66 / Electroless Nickel IAW AMS 2404C
For Cadmium/Olive Drab over Electroless Nickel Plating, insert "G" In Place Of "EM" In Part Number Development. Option "F" Has Been Superseded By "G".

S9407-AB-HBK-010
**Conduit Systems for Shipboard
 Electromagnetic Shielding**
 RP2210 Coupling, conduit-to-pipe



S9407-AB-HBK-010
**Conduit Systems for Shipboard
 Electromagnetic Shielding**
 RP2311 Adapter to MIL-DTL-5015 connector



CONDUIT-TO-PIPE COUPLING IAW S9407-AB-HBK-010 REV 2, RP2210

How To Order		
Sample Part Number	RP2210	-EM08
Basic Part Number	Conduit coupling	
Conduit Part No.	EM02, EM03, EM04, EM05, EM06, EM08, EM10, EM12, EM16, EM20, EM24 (See Material/Finish Note)	

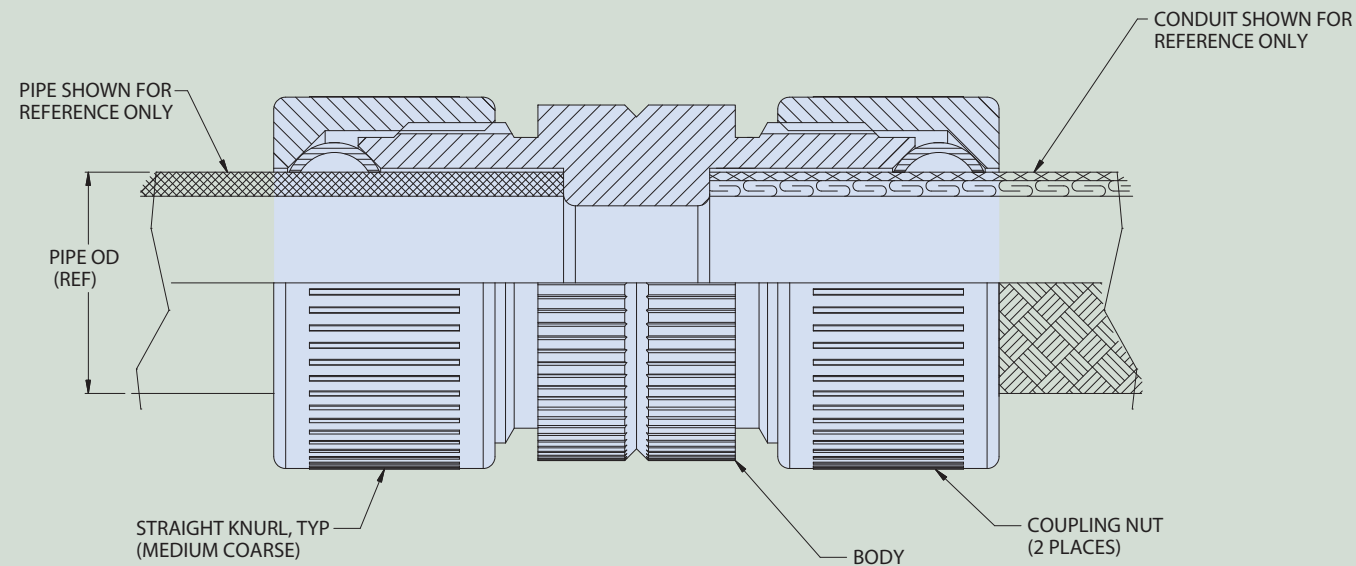

MATERIAL / FINISH

Body, Ferrule, Nut - Mild Steel AISI Type B1113 IAW Fed-STD-66 / Electroless Nickel IAW AMS 2404C
 For Cadmium/Olive Drab over Electroless Nickel Plating, insert "G" In Place Of "EM" In Part Number Development. Option "F" Has Been Superseded By "G".

ADAPTER TO M5015 CONNECTOR IAW S9407-AB-HBK-010 REV 2, RP2311

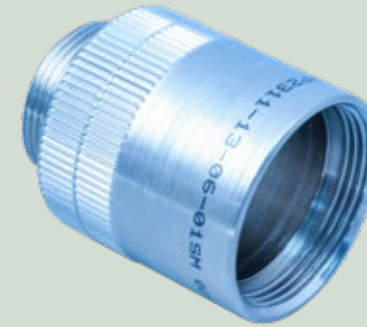

How To Order					
Sample Part Number	RP2311	-08	-08	-01	SM
Basic Part Number	Conduit adapter				
A Thread Code	01 - 31, see sales drawing for details				
Conduit Size Code	02, 03, 04, 05, 06, 08, 10, 12, 16, 20, 24				
Style Code	-01, 02, 03, see sales drawing for details				
Material / Finish	SN = mild steel with cadmium over electroless nickel finish SM = mild steel with electroless nickel finish IAW AMS 2404C (SM supersedes "no suffix" code reserved for legacy parts)				

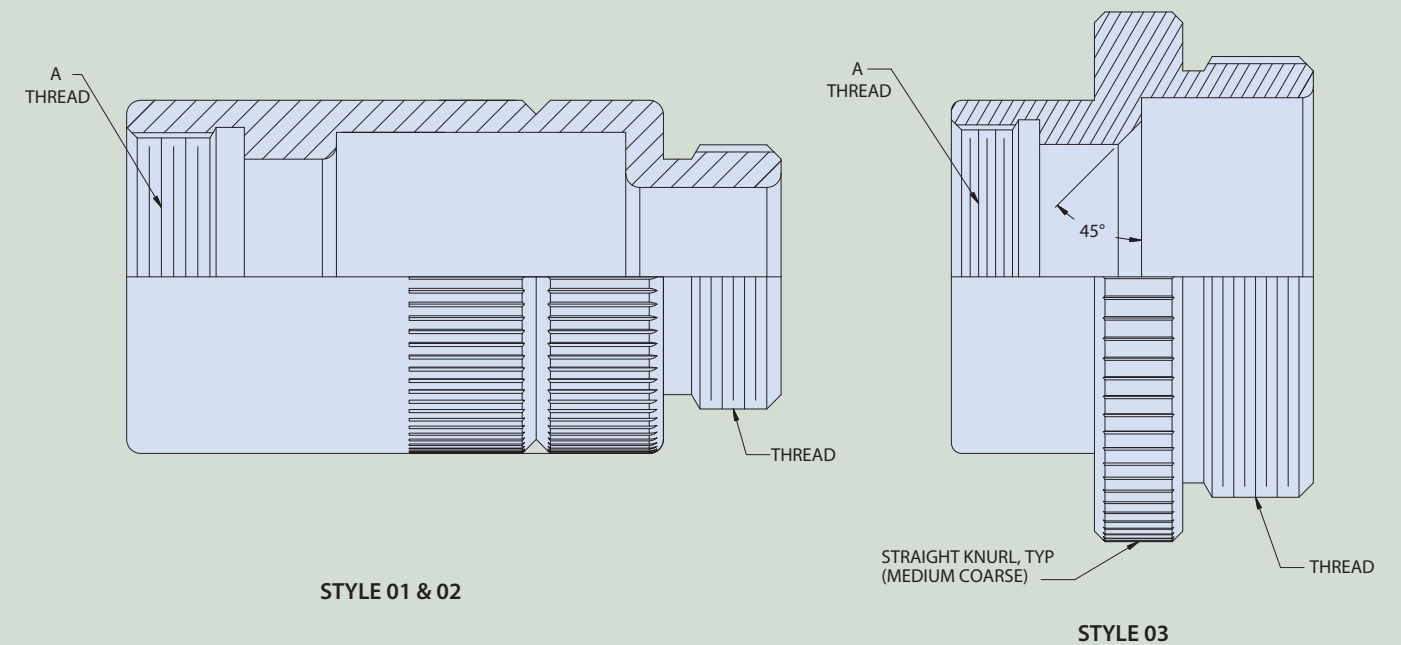

MATERIAL / FINISH

Body, Ferrule, Nut - Mild Steel AISI Type B1113 IAW Fed-STD-66

RP2000

RP2000



ADAPTER TO TRIAXIAL CONNECTOR IAW S9407-AB-HBK-010 REV 2, RP2321



How To Order				
Sample Part Number	RP2321	-08	-08	SM
Basic Part Number	Adapter to triaxial connector			
A Thread Code	01, 02, 03, 04			
Conduit Size Code	02, 03, 04, 05, 06, 08, 10, 12, 16, 20, 24			
Finish Symbol	SN = mild steel with cadmium over electroless nickel finish SM = mild steel with electroless nickel finish IAW AMS 2404C (SM supersedes "no suffix" code reserved for legacy parts)			

ADAPTER TO COAXIAL CONNECTOR IAW S9407-AB-HBK-010 REV 2, RP2330



How To Order				
Sample Part Number	RP2330	-02	-04	SM
Basic Part Number	Adapter to coaxial connector			
A Thread Code	02, 04, 06, 08, 10, 12			
Conduit Size Code	02, 03, 04, 05, 06, 08, 10, 12, 16, 20, 24			
Finish Symbol	SN = mild steel with cadmium over electroless nickel finish SM = mild steel with electroless nickel finish IAW AMS 2404C (SM supersedes "no suffix" code reserved for legacy parts) -N = Nylon			

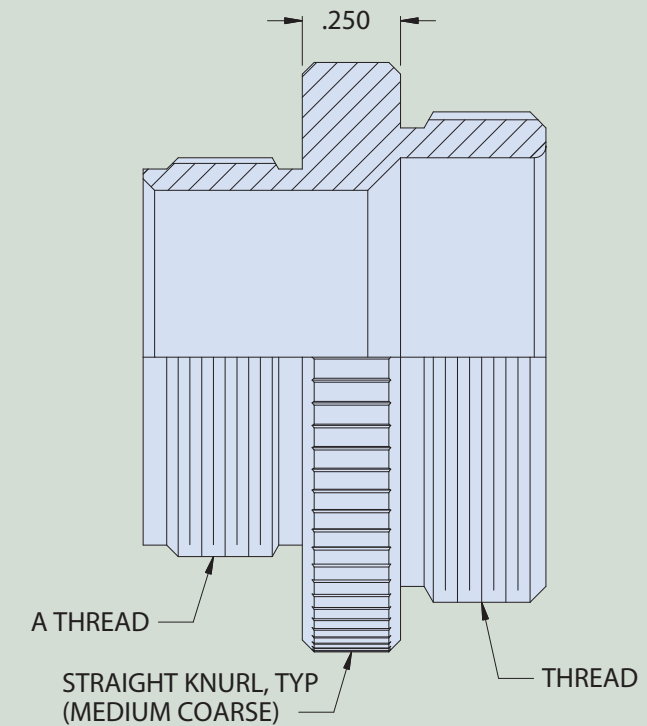
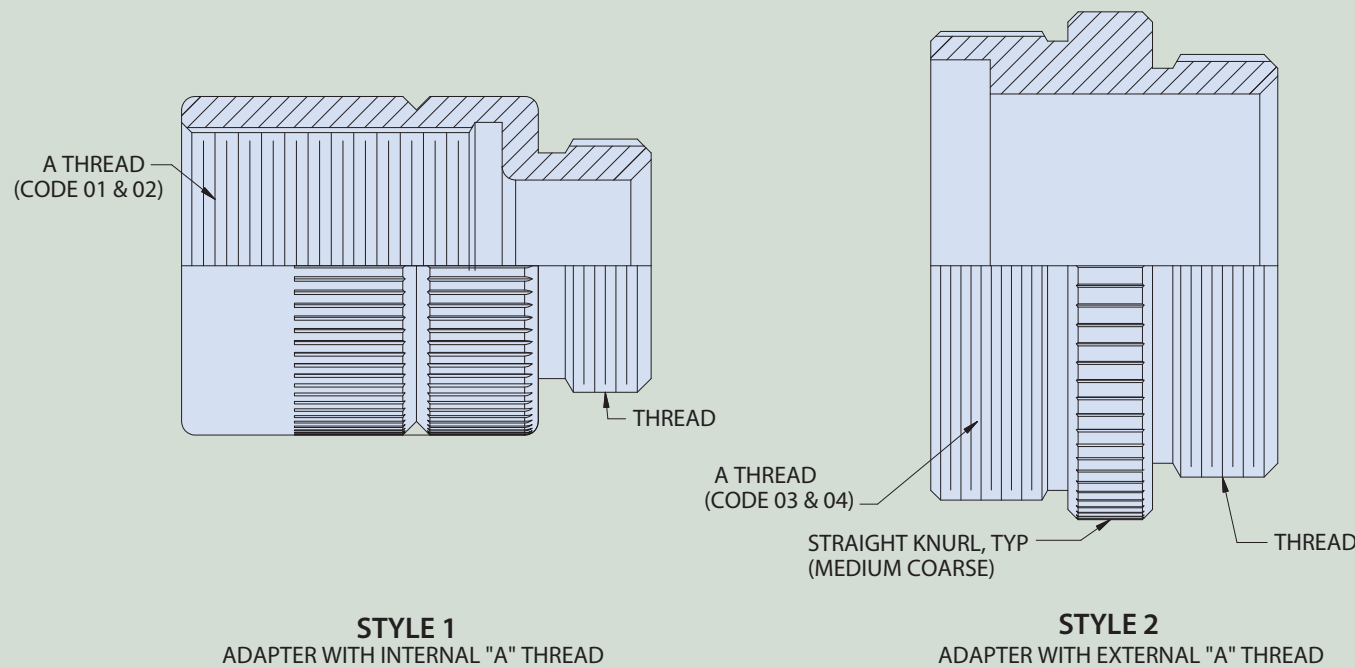

MATERIAL / FINISH

Body, Ferrule, Nut - Mild Steel AISI Type B1113 IAW Fed-STD-66
 RP2321 supersedes RP2320. Any requirement for an RP2320 will be satisfied with an RP2321

MATERIAL / FINISH

Adapter and Ferrule - Mild Steel AISI Type B1113 IAW Fed-STD-66
 or Nylon
 RP2321 supersedes RP2320. Any requirement for an RP2320 will be satisfied with an RP2321

RP2000

RP2000

S9407-AB-HBK-010

Conduit Systems for Shipboard Electromagnetic Shielding

RP2340 Adapter to MIL-C-26482 connectors



S9407-AB-HBK-010

Conduit Systems for Shipboard Electromagnetic Shielding

RP2350 Adapter to MS3155 type connectors



ADAPTER TO M26482 CONNECTOR IAW S9407-AB-HBK-010 REV 2, RP2340



How To Order	
Sample Part Number	RP2340 -15 -08 -03 SM
Basic Part Number	Adapter to M26482 connector
A Thread Code	07, 09, 11, 13, 15, 17, 19, 21, 23 see sales drawing for details
Conduit Size Code	02, 03, 04, 05, 06, 08, 10, 12, 16, 20, 24
Style Code	-01, 02, 03, see sales drawing for details
Material / Finish	SN = mild steel with cadmium over electroless nickel finish SM = mild steel with electroless nickel finish IAW AMS 2404C (SM supersedes "no suffix" code reserved for legacy parts)

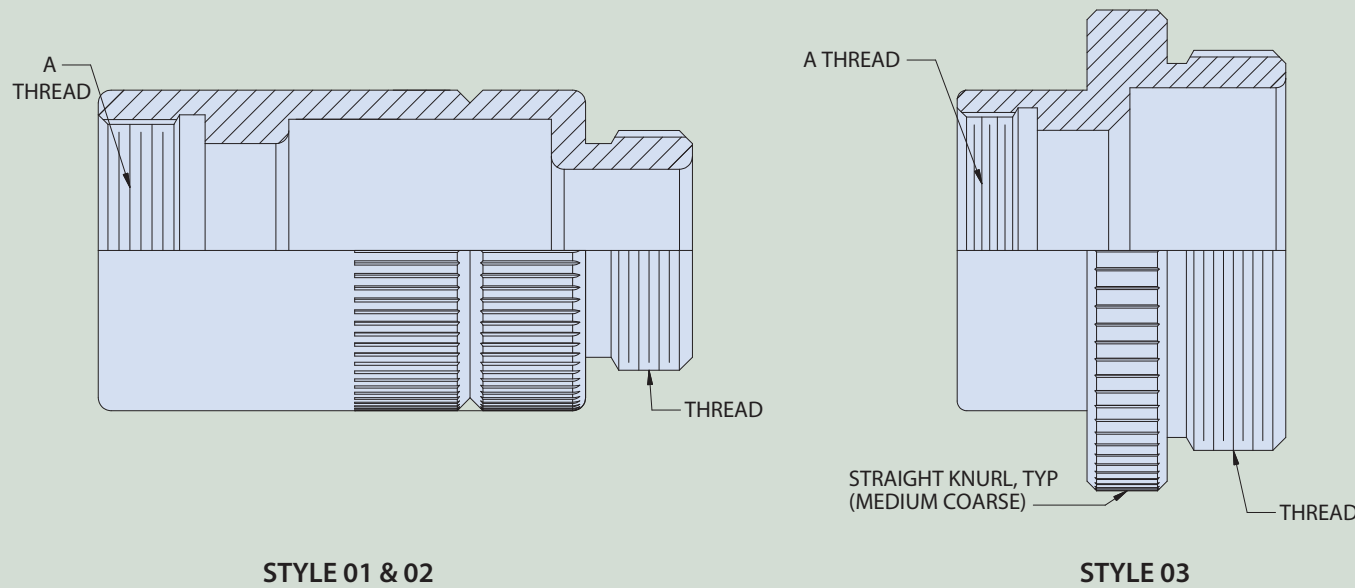

MATERIAL / FINISH

Mild Steel AISI Type B1113 IAW Fed-STD-66

NOTES

Style 01 - use when "E" diameter is greater than "K" diameter.
Style 02 - same as Style 01 except "J" dimension is zero.
Style 03 - use when "E" diameter is equal to or less than "K" diameter.
For MIL-C-26482 Series 2 the RP2350 adapter may be used

ADAPTER TO MS3155 CONNECTOR IAW S9407-AB-HBK-010 REV 2, RP2350



How To Order	
Sample Part Number	RP2350 -15 -06 -01 SM
Basic Part Number	Adapter to MS3155 connector
Connector Dash No.	03, 08, 10, 12, 14, 16, 18, 20, 22, 24, 28, 32, 26, 40, 44, 48, 61 see sales drawing for details
Conduit Size Code	02, 03, 04, 05, 06, 08, 10, 12, 16, 20, 24
Style Code	-01, 02, 03, see sales drawing for details
Material / Finish	SN = mild steel with cadmium over electroless nickel finish SM = mild steel with electroless nickel finish IAW AMS 2404C AM = Aluminum with electroless nickel finish IAW AMS 2404C ANF = Aluminum with cadmium O.D. over electroless nickel A = Aluminum with electroless nickel finish IAW AMS 2404C* Omit = mild steel with electroless nickel finish* *Finish Symbols "A" and "no suffix" are designed for legacy parts. These finish symbols have been superseded by "AM" and "SM" respectively.

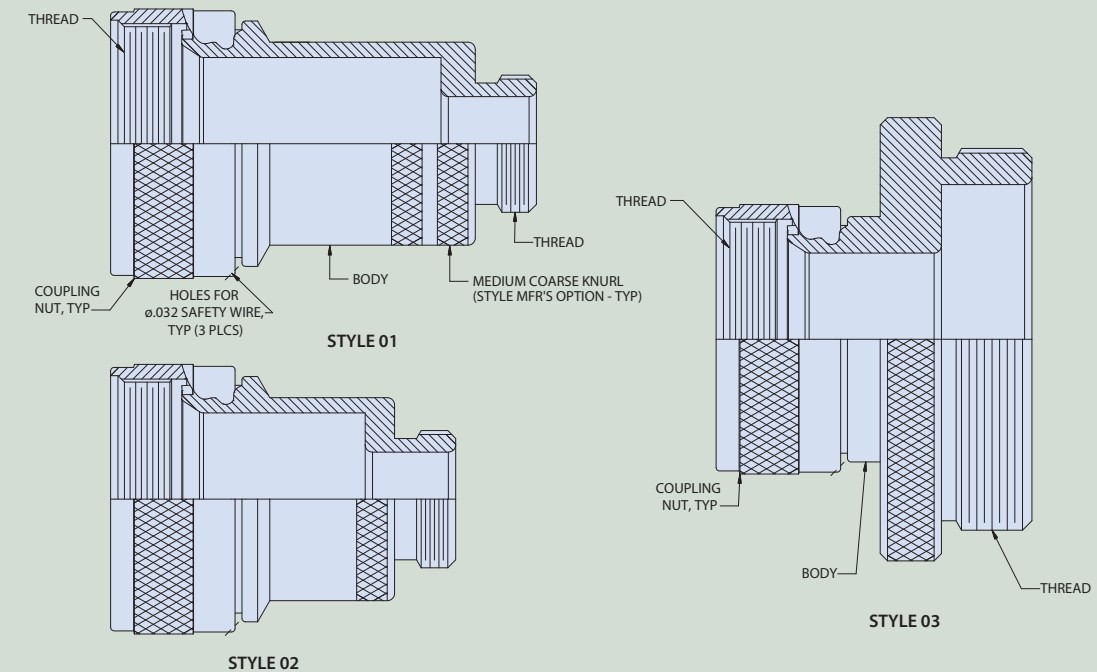

MATERIAL / FINISH

Mild Steel AISI Type B1113 IAW Fed-STD-66 or Aluminum Alloy IAW QQ-A-225 or ASTM-STD-885

NOTES

Style 01 - use when "E" diameter is greater than "K" diameter.
Style 02 - same as Style 01 except "Y" dimension is less than "J" dimension. Use when the extra working room provided by Style 01 is not a requirement.
Style 03 - "E" diameter is equal to or less than "K" diameter.

RP2000

RP2000

S9407-AB-HBK-010
**Conduit Systems for Shipboard
 Electromagnetic Shielding**



RP2360 Adapter for MIL-C-28840 (EC) backshell

ADAPTER TO M28840 BACKSHELL IAW S9407-AB-HBK-010 REV 2, RP2360

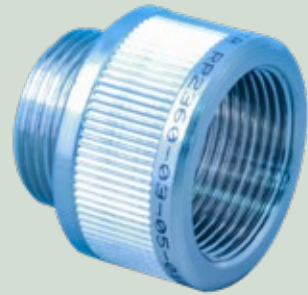

How To Order	
Sample Part Number	RP2360 -06 -08 -01 SM
Basic Part Number	Adapter to M28840 backshell
A Thread Code	01 - 15, see sales drawing for details
Conduit Size Code	02, 03, 04, 05, 06, 08, 10, 12, 16, 20, 24
Style Code	-01, 02, 03, see sales drawing for details
Material / Finish	SN = mild steel with cadmium over electroless nickel finish SM = mild steel with electroless nickel finish IAW AMS 2404C (SM supersedes "no suffix" code reserved for legacy parts)

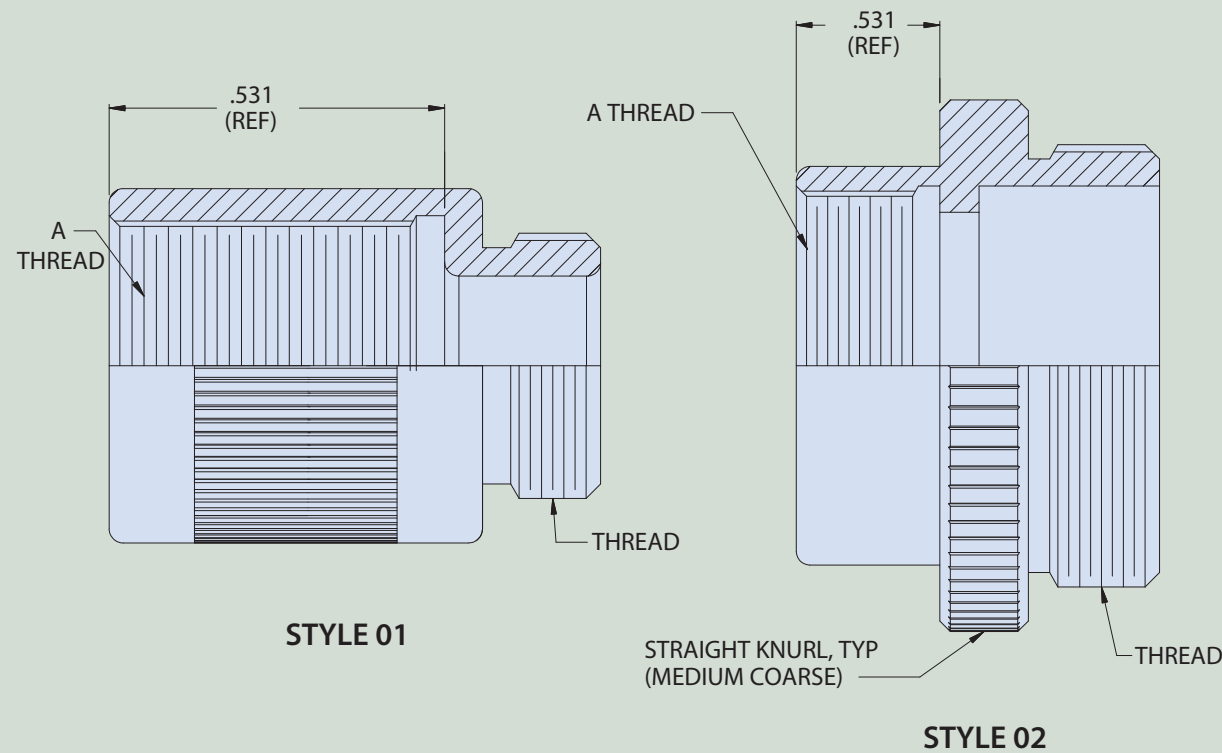

MATERIAL / FINISH

Mild Steel AISI Type B1113 IAW Fed-STD-66

NOTES

Style 01 - use when "K" diameter is smaller than "E" diameter of Style 02.
 Style 02 - use when "K" diameter is equal to or larger than "E" diameter.

S9407-AB-HBK-010
**Conduit Systems for Shipboard
 Electromagnetic Shielding**



RP2400 Adapter for MIL-S-24235/1 stuffing tube

ADAPTER TO M24235 STUFFING TUBE IAW S9407-AB-HBK-010 REV 2, RP2400



How To Order	
Sample Part Number	RP2400 -12 -10 SM
Basic Part Number	Adapter for M24235 stuffing tube
A Thread Code	02, 05, 08, 11, 12, 14, 15, 17, 18
Conduit Size Code	02, 03, 04, 05, 06, 08, 10, 12, 16, 20, 24
Material / Finish	SN = mild steel with cadmium over electroless nickel finish SM = mild steel with electroless nickel finish IAW AMS 2404C (SM supersedes "no suffix" code reserved for legacy parts)

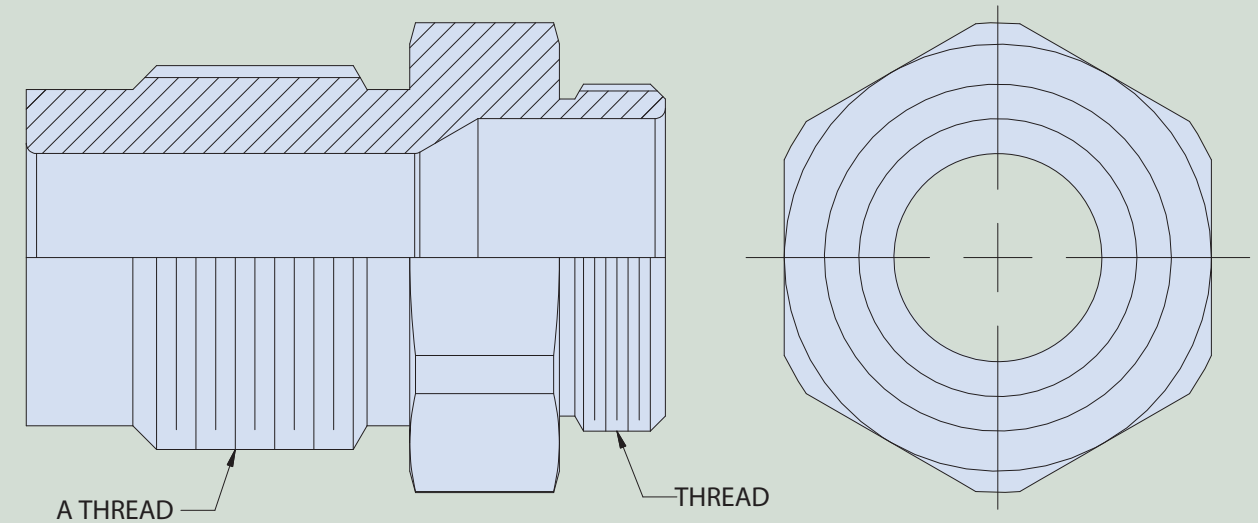

MATERIAL / FINISH

Mild Steel AISI Type B1113 IAW Fed-STD-66

RP2000

RP2000

S9407-AB-HBK-010

Conduit Systems for Shipboard Electromagnetic Shielding

RP2411 General-use threaded fitting adapter



S9407-AB-HBK-010

Conduit Systems for Shipboard Electromagnetic Shielding

RP2420 Adapter for MIL-C-24321 hull fitting



GENERAL-USE ADAPTER IAW S9407-AB-HBK-010 REV 2, RP2411

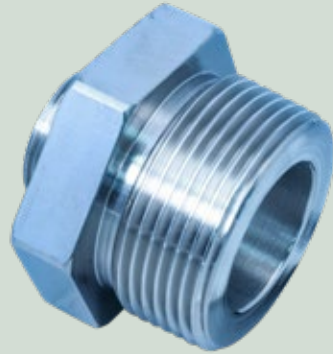

How To Order				
Sample Part Number	RP2411	-04	-08	SM
Basic Part Number	Adapter, general-use			
A Thread Code	01, 03, 04, 06, 07, 09, 10, 13, 16, 19, 20, 21			
Conduit Size Code	02, 03, 04, 05, 06, 08, 10, 12, 16, 20, 24			
Material / Finish	SN = mild steel with cadmium over electroless nickel finish SM = mild steel with electroless nickel finish IAW AMS 2404C (SM supersedes "no suffix" code reserved for legacy parts)			

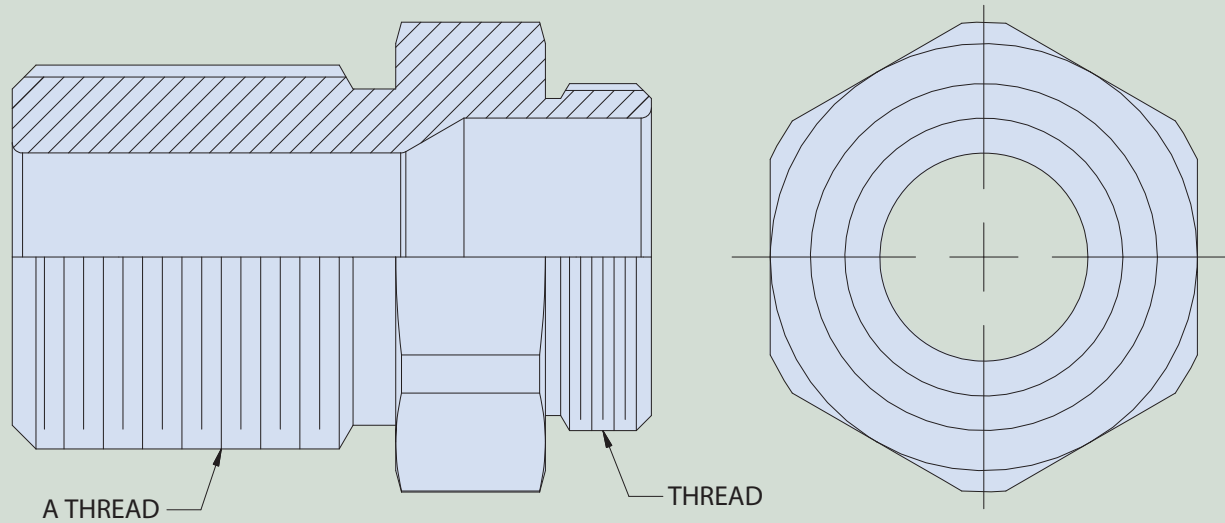

ADAPTER TO M24321 HULL FITTING IAW S9407-AB-HBK-010 REV 2, RP2420

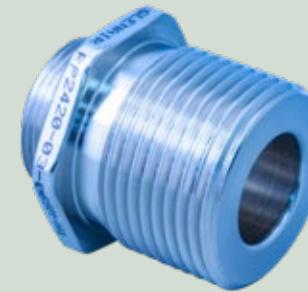

How To Order				
Sample Part Number	RP2420	-05	-12	SM
Basic Part Number	Adapter to M24321 hull fitting			
A Thread Code	01, 02, 03, 04, 05, 06			
Conduit Size Code	02, 03, 04, 05, 06, 08, 10, 12, 16, 20, 24			
Material / Finish	SN = mild steel with cadmium over electroless nickel finish SM = mild steel with electroless nickel finish IAW AMS 2404C (SM supersedes "no suffix" code reserved for legacy parts)			

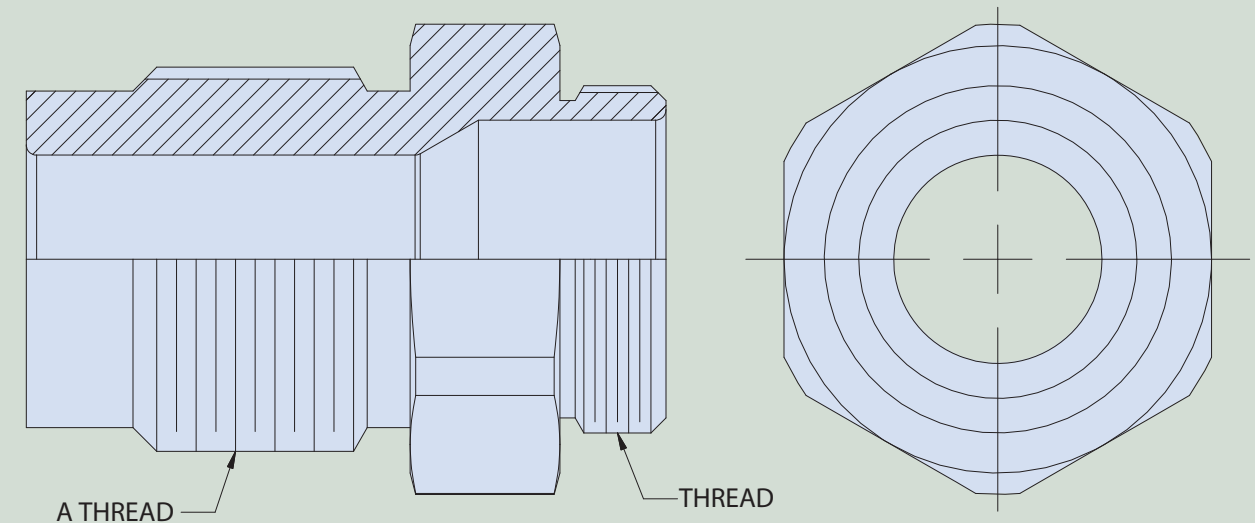

MATERIAL / FINISH

Mild Steel AISI Type B1113 IAW Fed-STD-66

MATERIAL / FINISH

Mild Steel AISI Type B1113 IAW Fed-STD-66

RP2000

RP2000

S9407-AB-HBK-010
**Conduit Systems for Shipboard
 Electromagnetic Shielding**



RP2430 Adapter for pipe thread (tapered)

TAPERED PIPE THREAD ADAPTER IAW S9407-AB-HBK-010 REV 2, RP2430

How To Order			
Sample Part Number	RP2430	-05	SM
Basic Part Number	Pipe thread adapter, tapered		
Conduit Size Code	02, 03, 04, 05, 06, 08, 10, 12, 16, 20, 24		
Material / Finish	SN = mild steel with cadmium over electroless nickel finish SM = mild steel with electroless nickel finish IAW AMS 2404C (SM supersedes "no suffix" code reserved for legacy parts)		

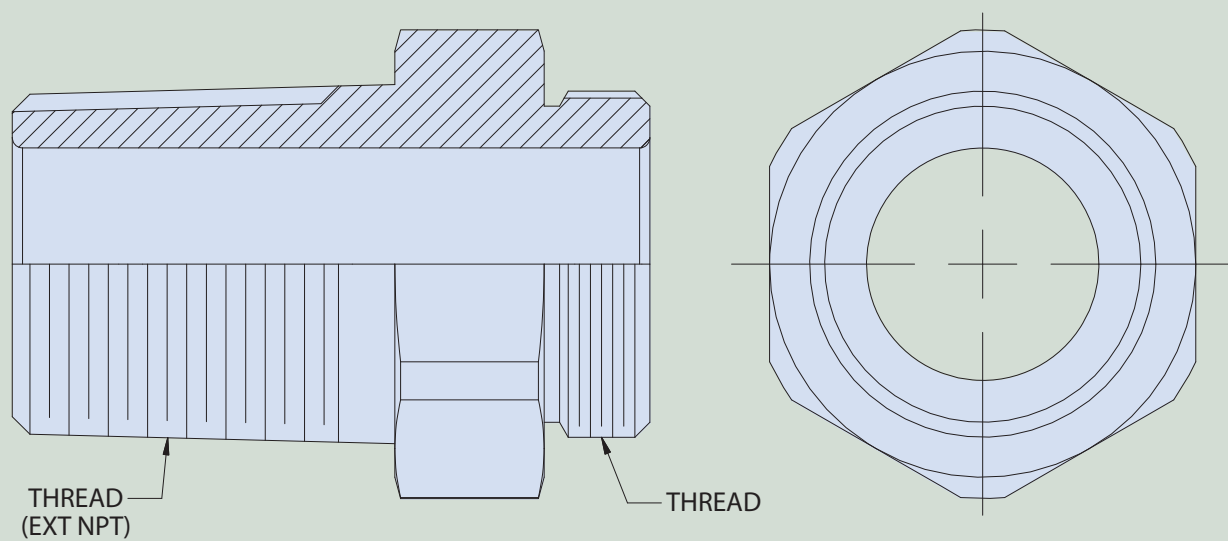

S9407-AB-HBK-010
**Conduit Systems for Shipboard
 Electromagnetic Shielding**



RP2431 Adapter for pipe thread (straight)

STRAIGHT PIPE THREAD ADAPTER IAW S9407-AB-HBK-010 REV 2, RP2431

How To Order			
Sample Part Number	RP2431	-06	SM
Basic Part Number	Pipe thread adapter, straight		
Conduit Size Code	02, 03, 04, 05, 06, 08, 10, 12, 16, 20, 24		
Material / Finish	SN = mild steel with cadmium over electroless nickel finish SM = mild steel with electroless nickel finish IAW AMS 2404C (SM supersedes "no suffix" code reserved for legacy parts)		

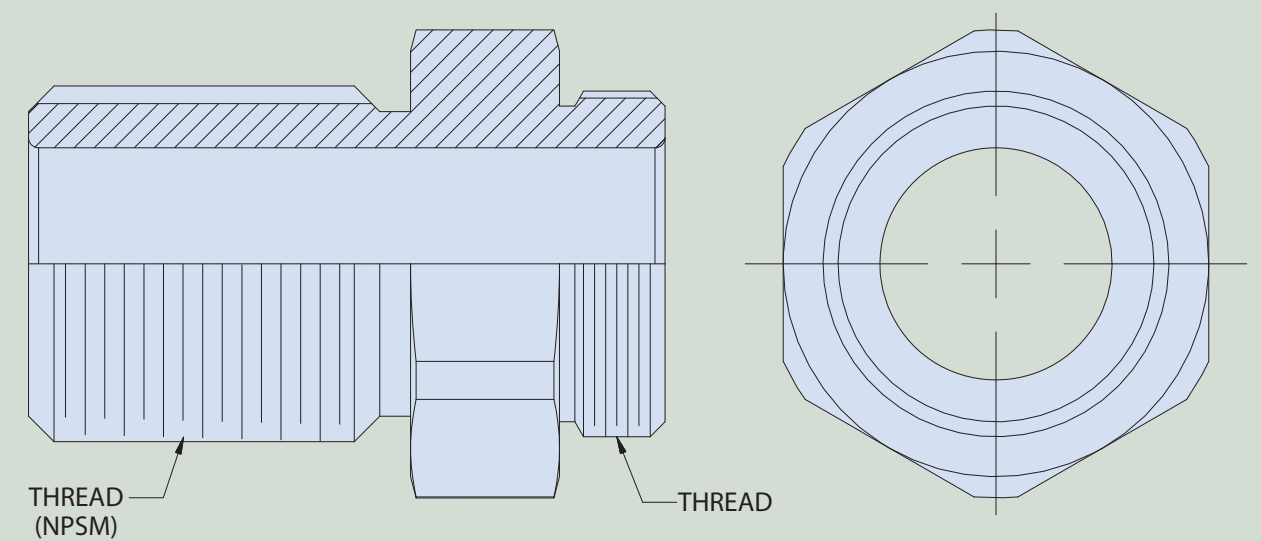

MATERIAL / FINISH

Mild Steel AISI Type B1113 IAW Fed-STD-66

MATERIAL / FINISH

Mild Steel AISI Type B1113 IAW Fed-STD-66

S9407-AB-HBK-010
**Conduit Systems for Shipboard
 Electromagnetic Shielding**

RP2440 Adapter, non-metallic (nylon)



S9407-AB-HBK-010
**Conduit Systems for Shipboard
 Electromagnetic Shielding**

RP2500 Adapter for panel termination



NON-METALLIC (NYLON) ADAPTER IAW S9407-AB-HBK-010 REV 2, RP2440



How To Order			
Sample Part Number	RP2440	-08	SM
Basic Part Number	Adapter, non-metallic		
Conduit Size Code	02, 03, 04, 05, 06, 08, 10, 12, 16, 20, 24		
Material / Finish	N = Nylon STN = Super Tough Nylon		

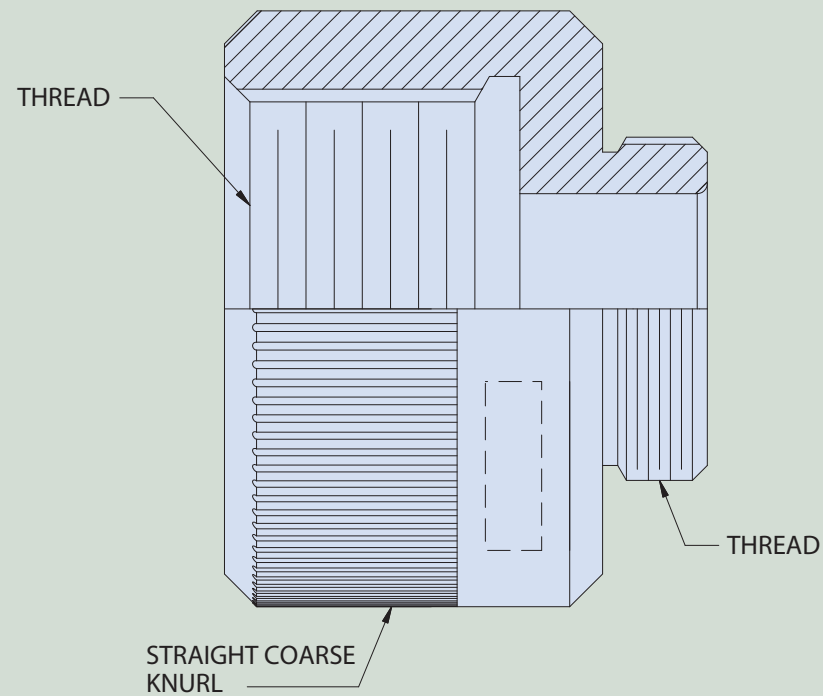

PANEL TERMINATION ADAPTER IAW S9407-AB-HBK-010 REV 2, RP2500



How To Order			
Sample Part Number	RP2500	-06	SM
Basic Part Number	Panel termination		
Conduit Size Code	02, 03, 04, 05, 06, 08, 10, 12, 16, 20, 24		
Material / Finish	SN = mild steel with cadmium over electroless nickel finish SM = mild steel with electroless nickel finish IAW AMS 2404C (SM supersedes "no suffix" code reserved for legacy parts)		

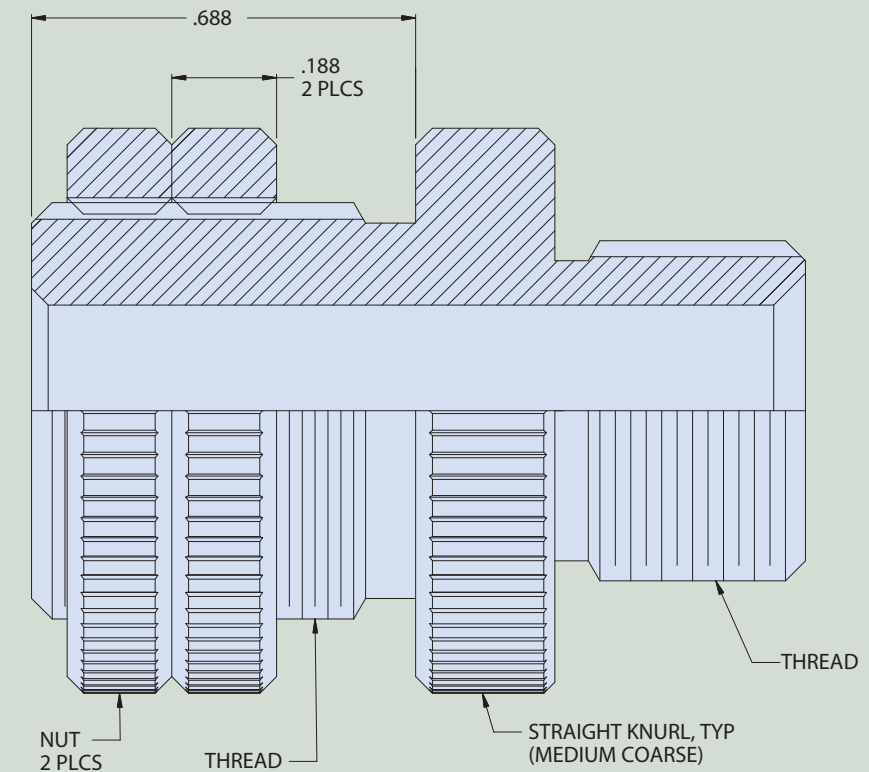

MATERIAL / FINISH

Mild Steel AISI Type B1113 IAW Fed-STD-66

RP2000

RP2000

S9407-AB-HBK-010
**Conduit Systems for Shipboard
 Electromagnetic Shielding**
 RP2610 90° adapter



S9407-AB-HBK-010
**Conduit Systems for Shipboard
 Electromagnetic Shielding**
 RP2620 45° adapter



90° ADAPTER IAW S9407-AB-HBK-010 REV 2, RP2610

How To Order			
Sample Part Number	RP2610	-06	SM
Basic Part Number	Adapter, 90°		
Conduit Size Code	02, 03, 04, 05, 06, 08, 10, 12, 16, 20, 24		
Material / Finish	SN = mild steel with cadmium over electroless nickel finish SM = mild steel with electroless nickel finish IAW AMS 2404C (SM supersedes "no suffix" code reserved for legacy parts)		

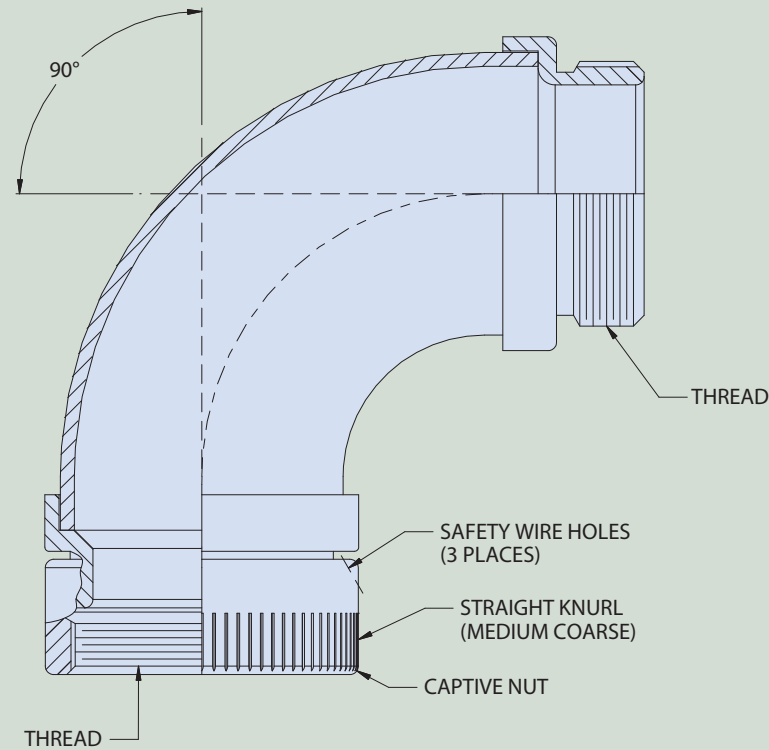

45° ADAPTER IAW S9407-AB-HBK-010 REV 2, RP2620

How To Order			
Sample Part Number	RP2620	-06	SM
Basic Part Number	Adapter, 45°		
Conduit Size Code	02, 03, 04, 05, 06, 08, 10, 12, 16, 20, 24		
Material / Finish	SN = mild steel with cadmium over electroless nickel finish SM = mild steel with electroless nickel finish IAW AMS 2404C (SM supersedes "no suffix" code reserved for legacy parts)		

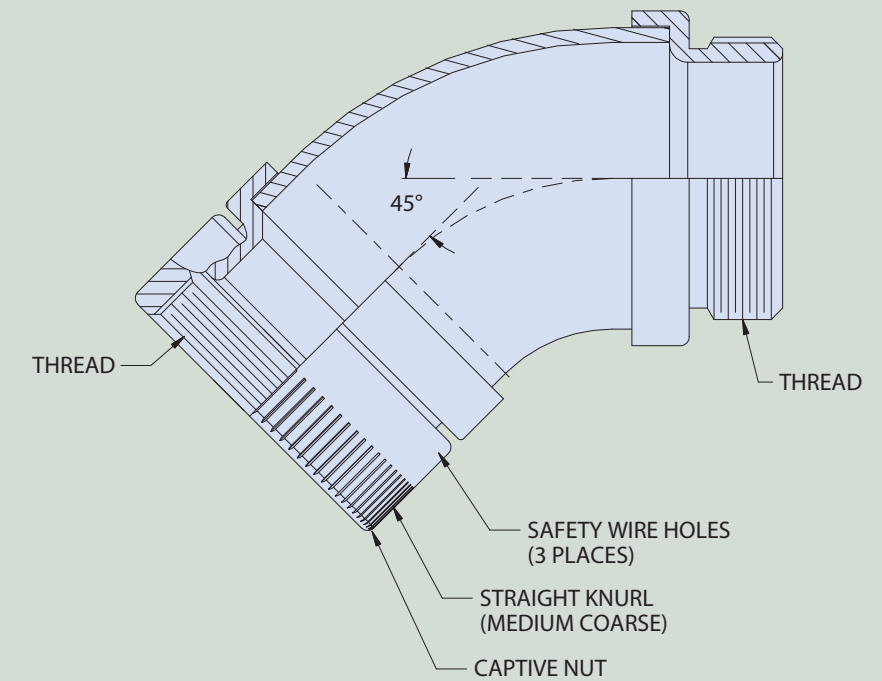

MATERIAL / FINISH

Mild Steel AISI Type B1113 IAW Fed-STD-66

MATERIAL / FINISH

Mild Steel AISI Type B1113 IAW Fed-STD-66

RP2000

RP2000

S9407-AB-HBK-010

Conduit Systems for Shipboard Electromagnetic Shielding

750-084 Flexible metal-core conduit with braided shield



S9407-AB-HBK-010

Conduit Systems for Shipboard Electromagnetic Shielding

750-085 Flexible metal-core conduit, braided shield/jacket



NICKEL-IRON CONDUIT WITH EMI/RFI BRAIDED SHIELD IAW S9407-AB-HBK-010, TYPE 1



How To Order			
Sample Part Number	750-084	-16	C
Basic Part Number	Flexible metal-core conduit with braid		
Dash No.	08, 09, 10, 12, 14, 16, 20, 24, 32, 40, 48, 64, 80, 96		
Compressed Core Option	C = Compressed Core Omit for standard uncompressed core		



NICKEL-IRON CONDUIT WITH EMI/RFI BRAIDED SHIELD AND ENVIRONMENTAL JACKET IAW S9407-AB-HBK-010, TYPE 2

How To Order			
Sample Part Number	750-085	-16	E
Basic Part Number	Flexible metal-core conduit with braid		
Dash No.	08, 09, 10, 12, 14, 16, 20, 24, 32, 40, 48, 64, 80, 96		
Jacket Material Option	Omit = standard Neoprene H = Hypalon E = EPDM V = Viton B = Bluejacket, Black G = Bluejacket, Gray TN = Bluejacket, Desert Tan		

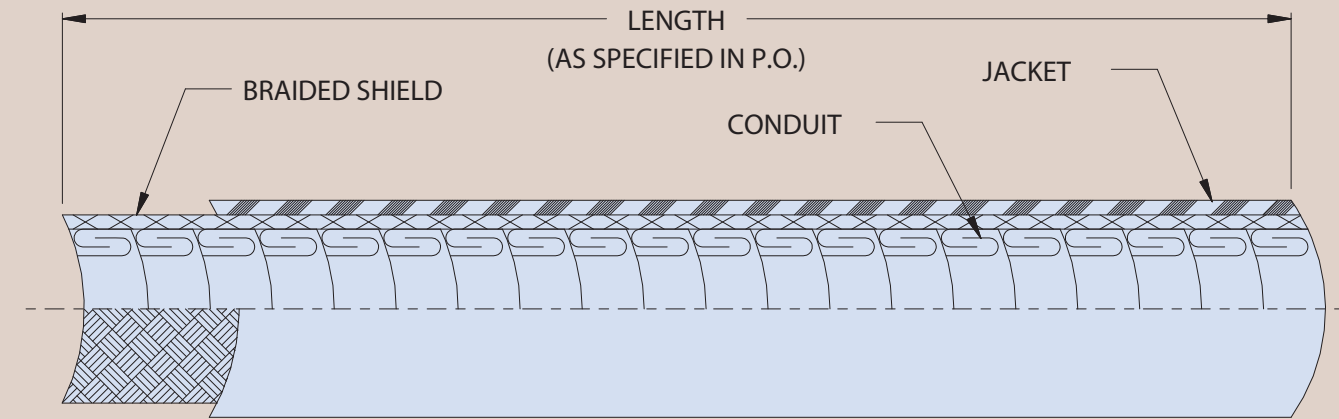
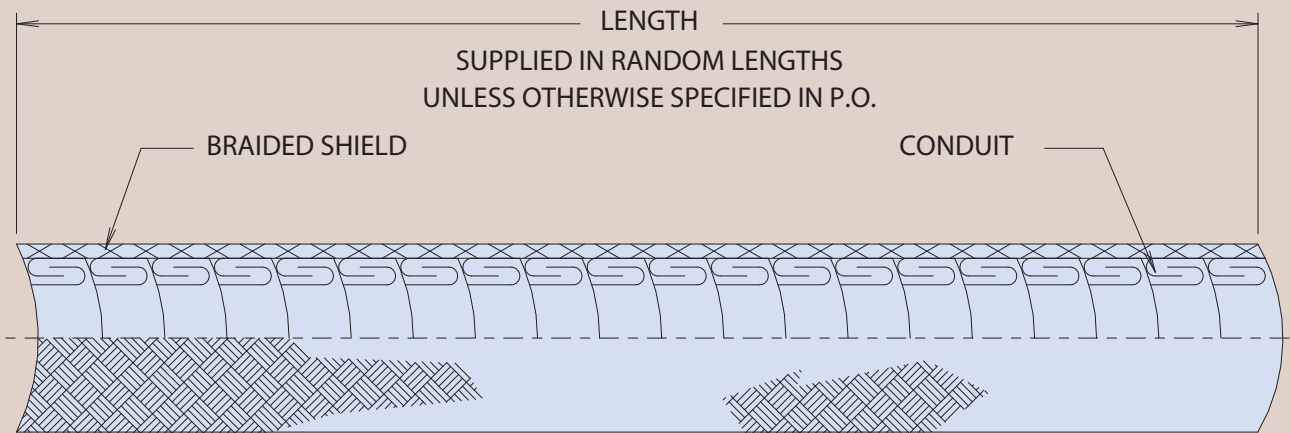

MATERIALS

Conduit - 80% Nickel, 20% Iron
Braided Shield - 304 CRES

MATERIALS

Conduit - 80% Nickel, 20% Iron
Braided Shield - 304 CRES
Jacket - Neoprene standard, black (.080 wall thickness)

METAL-CORE CONDUIT

METAL-CORE CONDUIT

Conduit Systems for Shipboard Electromagnetic Shielding



Shielding Effectiveness tables: Flexible Metal-Core Conduit

Conduit Systems for Shipboard Electromagnetic Shielding



Shielding Effectiveness tables: Flexible Metal-Core Conduit

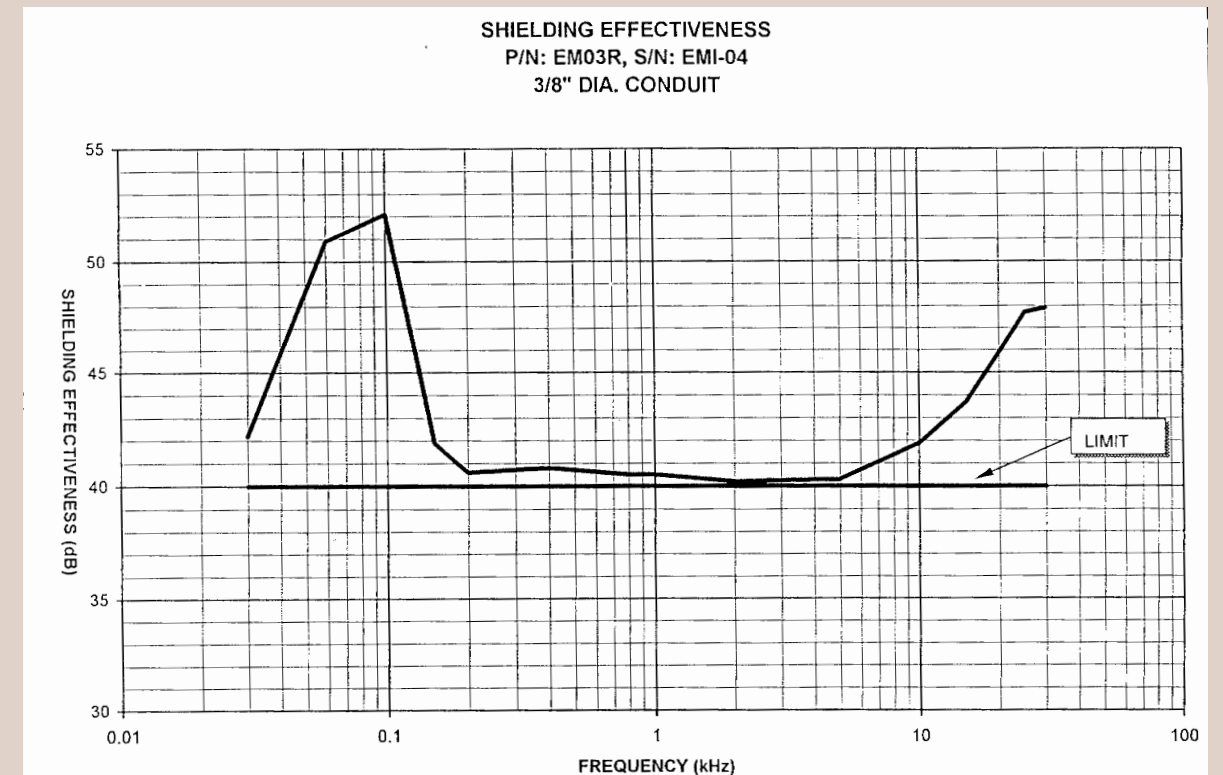
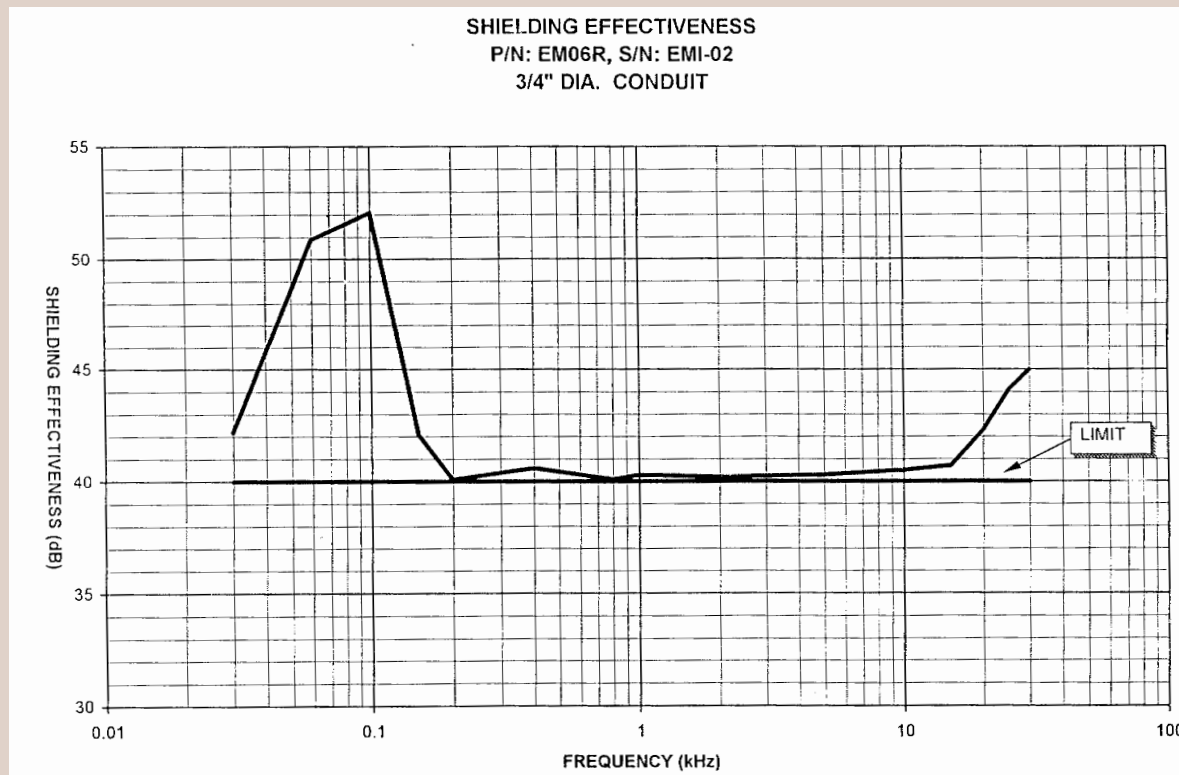
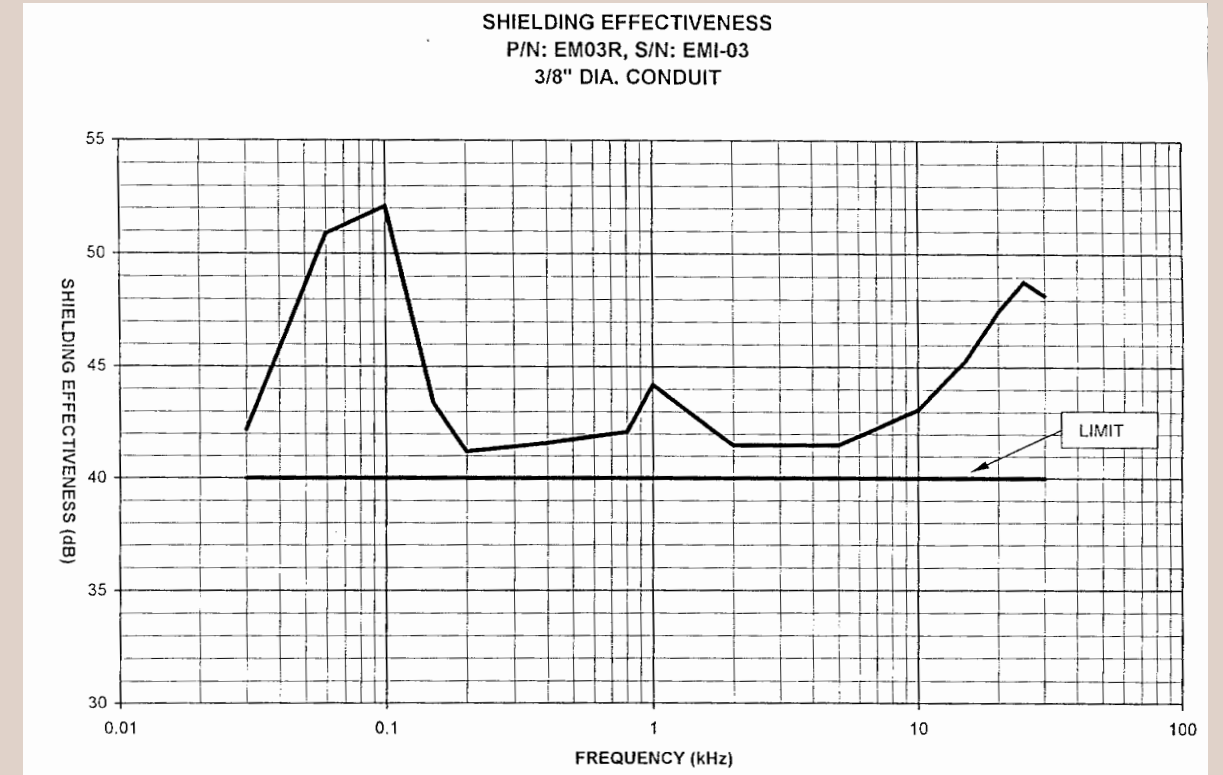
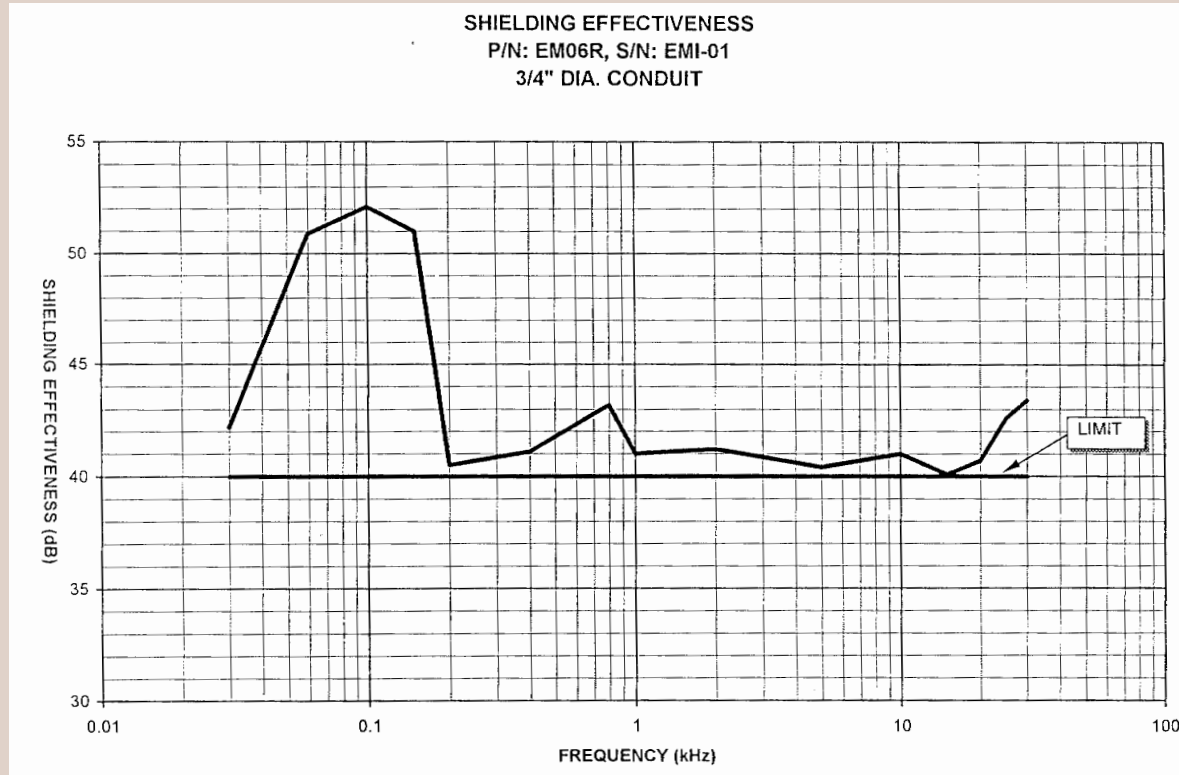

METAL-CORE CONDUIT

METAL-CORE CONDUIT



GROUNDING CLAMP FOR FLEXIBLE METAL-CORE CONDUIT

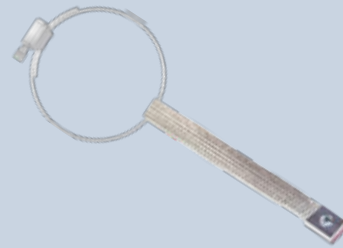

How To Order				
Sample Part Number	717-427	-01	E	12
Basic Part Number	Grounding clamp for flexible metal-core conduit			
Dash No.	01, 02, 03, 04, 05, 06			
Lug code	A, B, C, D, E, F, G, H			
Length in inches				

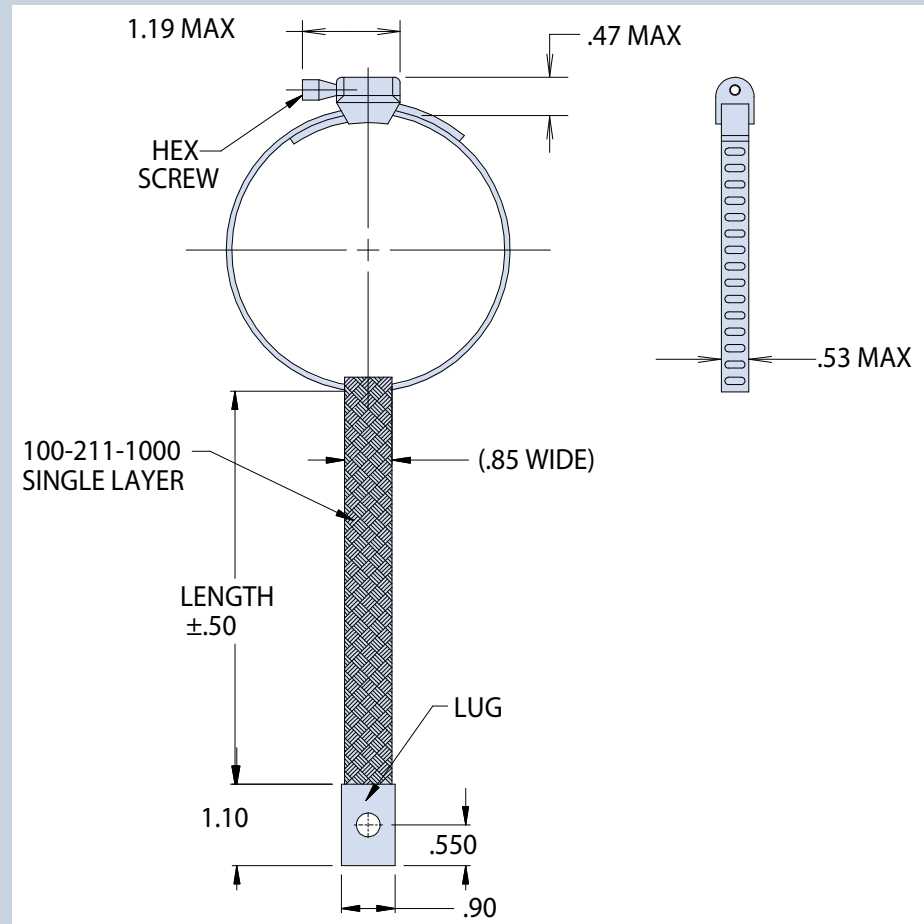

MATERIALS

Clamp and hardware - 300 Series SST / passivated
 Braid - 316L Stainless steel 36 AWG 50% / 200 Nickel 36 AWG 50%
 Lug - 316L Stainless steel / passivated

QPL MIL-DTL-24749 REV. C TYPE IV GROUND STRAPS



Glenair MIL-DTL-24749 Rev C Type IV ground straps solve harsh-environment shipboard corrosion and electrical resistance problems with a unique 50% Stainless Steel 316L / 50% Nickel 200 36AWG blend braid, and passivated Stainless Steel lugs. These US Navy-approved ground straps are qualified to the rigorous standards of M24749, and are tested beyond the mil-spec to survive 1000 hours salt spray. Allowed usages for Type IV straps can be found in MIL-STD-1310H.

How To Order					
Sample Part Number	M24749	-IV	-B	-L	-H
Product Series	MIL-DTL-24749 Rev. C Type IV bond strap				
Bond Strap Type	IV = Flat CRES 316 / Nickel 200 braid with mounting lugs				
Standard Size Code	A = 6.0" length; .90" width, .406 H dia. D = 6.0" length; .90" width, .282 H dia. B = 12.0" length, .90" width, .406 H dia. E = 12.0" length, .90" width, .282 H dia. C = 18.0" length, .90" width, .406 H dia. F = 18.0" length, .90" width, .282 H dia. N = for non-standard sizes				
Non-Standard Length	Non-Standard length in inches (omit for standard sizes)				
Hole Diameter	Non-Standard diameter in inches (omit for standard sizes)				

- Meets the rigorous specifications of MIL-DTL-24749 Rev. C
- Tested to survive 1000 hours salt spray
- Unique Stainless Steel/Nickel hybrid braid
- Available in six standard configurations, with non-standard length/lug size configurations available

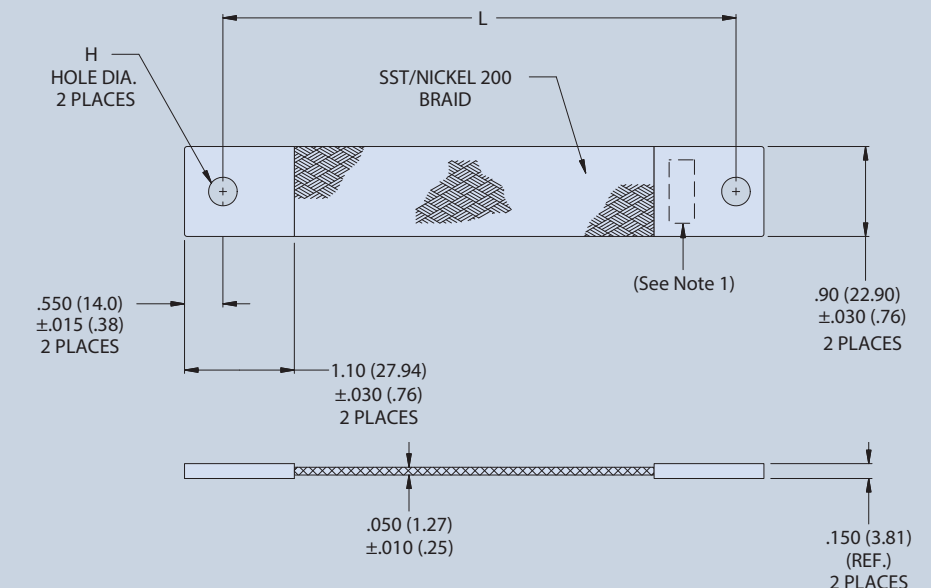

NOTES

- Lugs are ink stamped or electro-etched per M24749 Rev. C Min. character height .06 (1.52)
- Codes A - F are standard lengths. To order non-standard straps, omit Standard Size Code and enter length (in inches) in part number.

MATERIAL/FINISH

Lugs - 316L Stainless Steel/Passivate
 Braid - 316L Stainless Steel 36 AWG, 50%; 200 Nickel 36 AWG, 50%

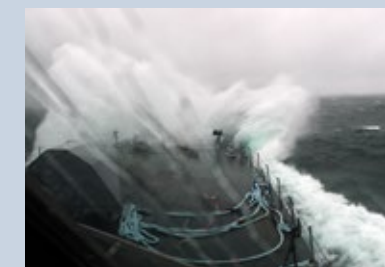

Glenair MIL-DTL-24749 Rev. C Type IV Stainless Steel/Nickel Ground Straps: US Navy qualified and tested to survive extreme environments

GROUNDING

GROUNDING



Fast and easy cold-action shrink boot and tubing solutions

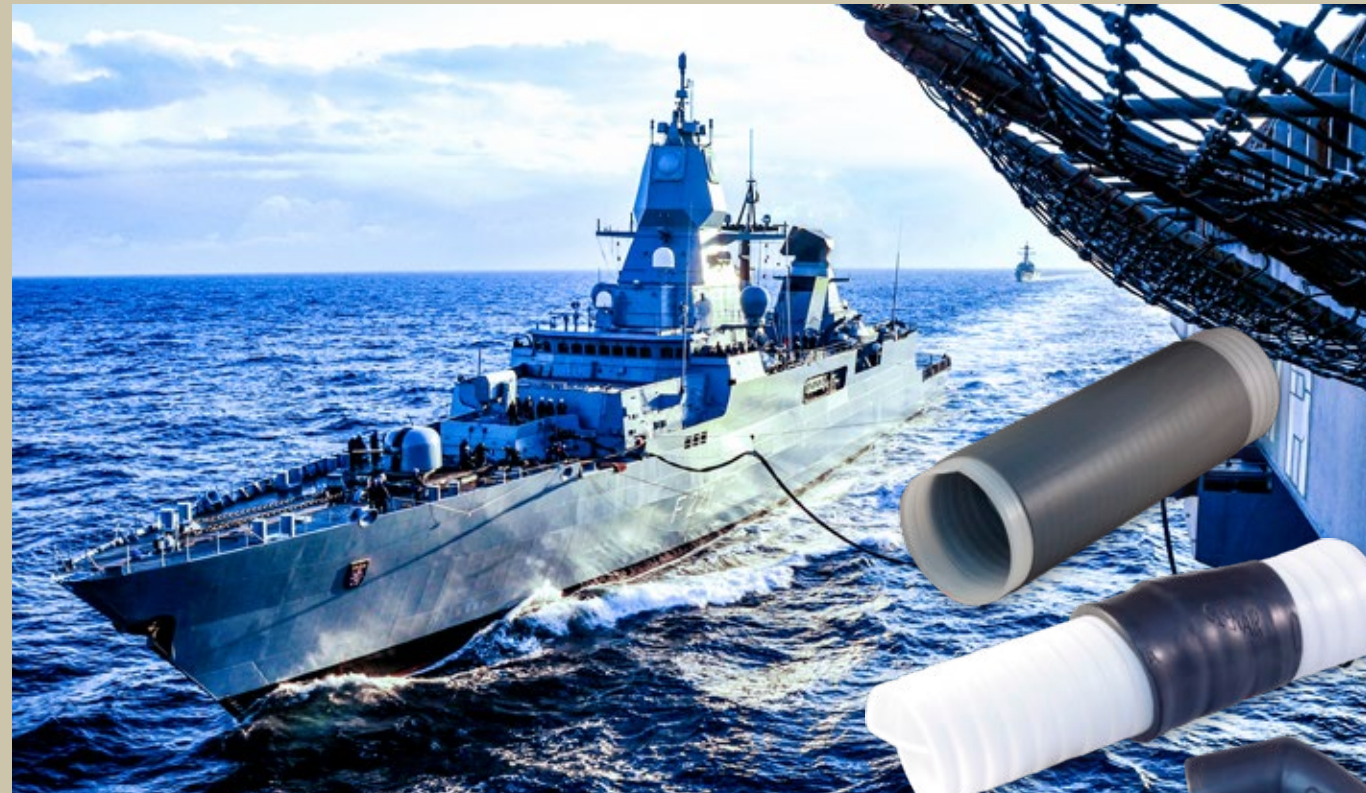

Designed for rugged weathering, UV and ozone-resistant performance, Glenair AutoShrink is the one-piece easy-action shrink boot and tubing solution. Quickly attach shrink boots, splice insulation, or repair Glenair Duraelectric formula jacketing. Straight, 45° and 90° angle lipped shrink boots lock into boot groove on adapters to keep out environmental debris. Universal design AutoShrink tubing delivers reliable and durable sealing as well as mechanical protection for cable-end terminations in harsh military and industrial applications. Built from Glenair Duraelectric formula material, AutoShrink is fully hydrophobic and resistant to caustic chemicals and solvents. Easy-action spiral hold-out and large cold shrink ratio makes for fast installation and durable, split-resistant performance.

- Straight, 45° and 90° angle-lipped shrink boots and shrink tubing
- Fast and easy installation
- Four high-performance material types
- Fire-resistance in all material types
- Reliable IP68 sealing
- 3000 VAC rated
- Multiple color options
- Service temperature range: -65°C to 300°C
- Ideal for repair of cables and conduit with Duraelectric jacketing
- Extreme UV / sunlight resistance
- Integrated ground strap versions available



Mil-Aero / Industrial fluid-resistant lipped shrink boots

Fast and easy repair of Duraelectric-jacketed cables

Utilize for termination of lugs on new installations



Fast cold-action shrink tubing for environmental protection of conduit-to-fitting transitions and jacket repair

FOR REPAIR OF CONDUIT JACKETING AND ENVIRONMENTAL PROTECTION OF CONDUIT ADAPTERS

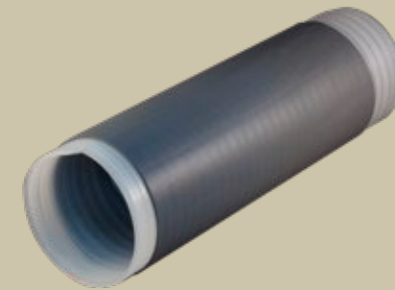

How To Order				
Sample Part Number	777-004	-01	-6	-0
Product Code-Basic No.	AutoShrink			
Size Code	See Table I			
Length	in Inches. 3" min., 12" max.			
Color Code	See Table II			

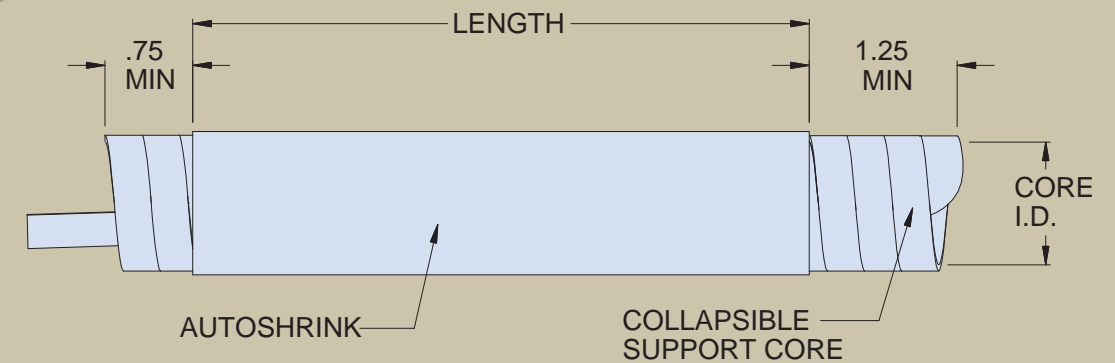

Code	Color	Reference
0	Black	FED-STD-595C; #17038
1	Desert Tan	FED-STD-595C; #33446
2	Red	FED-STD-595C; #11120
3	Orange	FED-STD-595C; #12300
4	Yellow	FED-STD-595C; #13591
5	Green	FED-STD-595C; #14193
6	Blue	FED-STD-595C; #15125
7	Purple	FED-STD-595C; #17142
8	Gray	FED-STD-595C; #26270
9	White	FED-STD-595C; #17875

Dash No.	Tube I.D. after unrestricted shrinkage (ref)		As Supplied Core I.D.		Ref. Wire Bundle Range min / max	
	In.	mm	In.	mm	In.	mm
01	0.250	6.4	0.80	20.3	0.35 / 0.65	8.9 / 16.5
02	0.375	9.5	1.18	30.0	0.55 / 1.00	14.0 / 25.4
03	0.625	15.9	2.00	50.8	0.85 / 1.65	21.6 / 41.9
04	0.750	19.1	2.34	59.4	1.00 / 2.00	25.4 / 50.8
05	0.937	23.8	2.75	69.9	1.25 / 2.50	31.8 / 63.5
06	1.437	36.5	4.00	101.6	2.00 / 3.85	50.8 / 97.8

NOTES

Length in expanded form may be less than length after unrestricted shrinkage.
 Material: Duraelectric per GPS67-E1. • Extruded wall thickness: .062
 779-005 Adhesive (sold separately) may be specified for applications that require extraordinary environmental sealing performance

MASTER SEAL SELF-VULCANIZING REPAIR TAPE

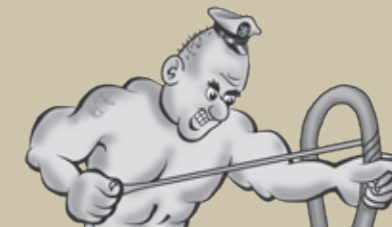

Order Part Number 687-758

Designed for temporary repairs to topside conduit, Glenair Master Seal stops water incursion into conduit until a permanent repair using MIL-PRF-24758A Conduit can be effected.

WIRE PROTECTION



NAVSEA-Approved Shielded Composite Junction Boxes



Durable, lightweight corrosion-free EMI/RFI shielded composite junction boxes NAVSEA standard drawing 803-6983506 Rev. B

- Over a dozen different tooled sizes and shapes.
- Extremely durable, corrosion-free, high temperature engineering composite thermoplastic
- Tested and qualified to U.S. Navy, UK MOD and hundreds of commercial aircraft and marine applications

Series 316 stainless steel hardware provides long-term durability

Unlimited corrosion resistance compared to metal junction boxes reduces repair and maintenance costs.

Glass reinforced composite thermoplastic material is strong and durable, yet extremely lightweight.



IP67 rated seals and gaskets protect equipment from moisture and dust

Example box shown: one of a series of NAVSEA-approved signal, switch, sound power, control boxes designed to eliminate corrosion damage and reduce maintenance cost on Navy ships

NAVSEA-APPROVED Composite Junction Boxes for Naval applications



TESTED AND QUALIFIED THROUGHOUT THE FLEET: GLENAIR CORROSION-FREE COMPOSITE BOXES



Broad range of sizes and shapes

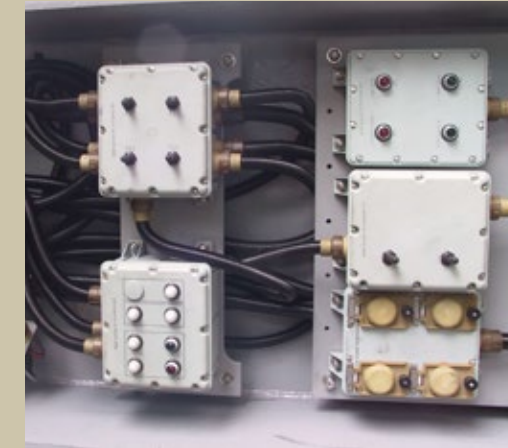

Complex installations fully supported with feed-thru fittings and wire protection conduit

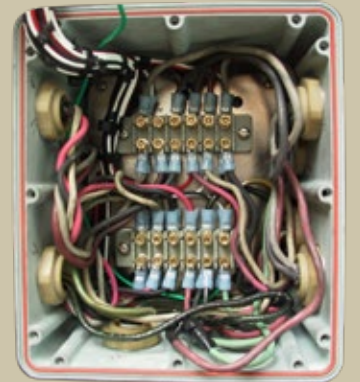

Discrete components or turnkey wired and connectorized systems

Glenair Composite Box Product Specifications		
Description/Test Report	Requirement	Procedure
Plating Adhesion <i>Glenair #9-44-18/TN94-159</i>	Should not exhibit any blistering, peeling or other separation of the units plating.	Tested IAW MIL-DTL-38999.
Vibration <i>NTS #973-7369-2</i>	Should not exhibit loosening of component parts or evidence of damage.	Tested IAW MIL-STD-167 Type 1 for box units and MIL-STD-1344, Method 2004 Condition II for fittings and accessories.
Shock <i>MOD #BR8470 Grade C and F</i>	There shall be no loosening of parts or evidence of damage.	Tested IAW MOD BR 8470 Grade C and F.
Salt Spray <i>Glenair #9-44-18/TN94-159</i>	Should exhibit no exposure of underplate or base material.	Tested IAW MIL-STD-1344, Method 1001.
Dust <i>NTS #973-7369-1</i>	Should conform to required torque limits and functional requirement within 25%.	Tested IAW MIL-STD-202.
UV Light Resistance <i>GE RDM88050255-6042</i>	No degradation of the mechanical properties defined in the specification after testing.	Tested IAW ASTM D2565.
Impact <i>MIL-STD-1344, Method 2018</i>	No evidence of breaking or cracking of components or other damage that could affect the product performance.	Tested IAW MIL-STD-1344, Method 2018.
Temperature Cycling <i>NTS #575-9249</i>	No cracking, peeling or separation of plating or other functional damage.	Tested IAW MIL-STD-1344, Method 1003 at -65°C to 200°C.
Hydrolytic Stability <i>NTS #878-536</i>	No evidence of increased weight greater than 1% and no evidence of cracking, breaking or loosening of component parts.	Tested IAW ASTM D570-81.
Flammability <i>MIL-STD-1344, Method 1012, Smoke Index, NES 711 Issue 2, NES 713 Issue 3 and ISO 4589</i>	The item flame and after flow extinguishing time shall not exceed the defined limits.	Tested IAW Table II of MIL-STD-1344, Method 1012, Smoke Index, NES 711 Issue 2, NES 713 Issue 3. Burning behavior by Oxygen Index, ISO 4589.
Water Tightness <i>EA #0C13513-039514</i>	Water tightness and internal pressurization is maintained.	Tested IAW EA #0C13513-039514.
Outgassing <i>JPL #081892</i>	Maximum allowable weight loss is 10%.	Tested IAW ASTM E 595.
Electromagnetic Shielding <i>TRW/ABQ-55C-1186-0</i>	Should demonstrate shielding effectiveness and transfer impedance conforming to military industry standards and specific customer requirements.	Tested IAW TRW/ABQ-55C-1186-0.



Outstanding repositionable backshell for harsh-environment applications



Designed for use in rugged shipboard applications as well as military ground systems such as armored vehicles, the Glenair BacNav OFS delivers outstanding mechanical, electrical, and environmental performance. The innovative design incorporates an environmentally-sealed, EMI shielded core with a locking pivot that facilitates cable routing and eliminates the need to stock discrete straight, 45° and 90° variants of standard wire sealing, strain relief, and EMI shield termination backshells. Built to withstand the handling abuse that topside and below-deck electrical and fiber optic interconnect systems are routinely subjected to by ham-fisted sailors and marines, the BacNav OFS is purpose-designed to deliver life-of-ship and life-of-system performance and durability. Available for the broad range of power, signal, and fiber optic connector systems—including MIL-PRF-28876 and MIL-PRF-64266 (fiber optics) to MIL-DTL-28840, AS50151, and more—BacNav OFS meets every current requirement for backshell-equipped connectorized cabling.

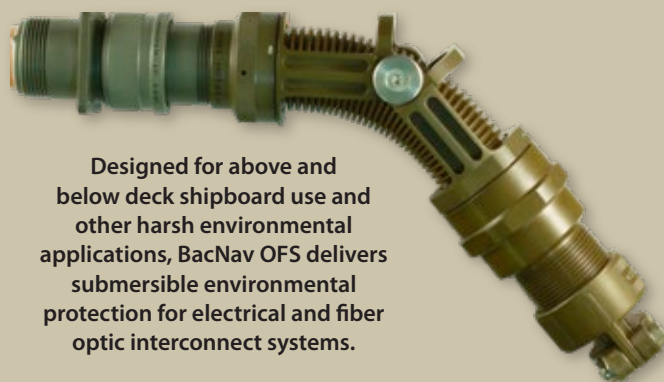

Designed for above and below deck shipboard use and other harsh environmental applications, BacNav OFS delivers subsersible environmental protection for electrical and fiber optic interconnect systems.

- Easy repositioning from straight, 45° and 90° cable-exit orientations
- Submersible performance without the need for shrink boots
- Durable, flexible EMI/RFI and environmentally-sealed core with locking-pivot Swing-Arm™ frame
- Accommodates power, signal and fiber optic jacketed cables
- Reposition terminated cables with no impact on signal integrity or system performance
- Easy repeatable assembly process using standard tools

BacNav OFS repositionable harsh-environment backshell

Outstanding, flexible performance

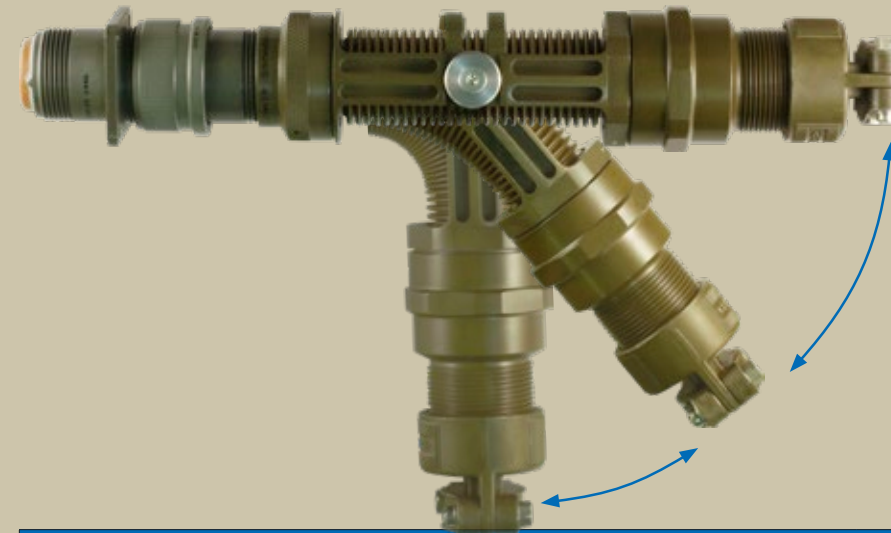

BacNav OFS is the only fully-sealed EMI/RFI backshell and strain relief device that delivers fast and easy cable angle configuration in the field—using a common 7/64" hex wrench, and without decoupling from the connector and/or cable. The sealed, flexible connector backshell adjusts to straight, 45° and 90° cable angles with zero impact on signal integrity or system performance.

PERFORMANCE DATA		
DESCRIPTION	REQUIREMENT	STANDARD
Magnetic permeability	Less than 2.0μ	EIA-364-54
Shell conductivity	< 2.5 milliohms ⁽²⁾	EIA 364-83
Salt spray (corrosion)	No exposure of basis material as defined in AIR4789 for 500 hours ⁽²⁾	EIA 364-26
Vibration	CIT <0.5dB No discontinuities ⁽¹⁾ No damage	MIL-STD-167-1A (SHIPS), paragraph 5.1.2.4.6 (endurance test)
Shock	CIT <0.5dB No discontinuities ⁽¹⁾ No damage	MIL-S-901D, grade A, Class 1
Water pressure	10 meters for 48 hours (IP68)	QTP-384
Cable pullout	No slippage exceeding 1/8" CIT <0.5dB ⁽¹⁾	EIA 364-38 TIA-455-6
Coupling thread strength	No damage at 3X magnification	AS85049 (Heavy Duty)
External bending moment	300-750 in-lbs (size dependant)	AS85049 (Heavy Duty) QTP-384
Fluid immersion	No changes detrimental to performance ⁽²⁾	EIA 364-10
Insertion loss	MIL-STD-1678-2 Appendix C, Table 2101 C-I	TIA-455-34 Method A
Cable seal flexing	100 cycles/axis	TIA-455-1
Twist	50 cycles • No damage/leaks	TIA-455-36
Impact	8 drops • No damage detrimental to performance	TIA-455-2 Method B
Crush	7 cycles 1,250 N (281 lbs)	TIA-455-26
Thermal Shock	5 cycles -40°C to +85°C (-40°F to +185°F)	TIA-455-71
Temp/humidity cycling	No damage detrimental to performance	TIA-455-5 Method B
Temperature cycling	No damage detrimental to performance	TIA-455-3
Life Aging	10 cycles	QTP-384-F
Freezing water immersion	No damage detrimental to performance	TIA-455-98
Sand and dust	No damage detrimental to performance	TIA-455-35
Modified SO2/salt spray	240 hours • No damage detrimental to performance ⁽²⁾	ASTM G85 + Annex A4

⁽¹⁾ Tested with MIL-PRF-28876 Multi-mode Fiber-Optic connectors ⁽²⁾ Tested with Cadmium/Olive-Drab finish option (code NF)

MORE ADVANCED GLENAIR BACKSHELL TECHNOLOGY: FIREWALL AND PRESSURE BOUNDARY FEED-THRU



- High-grade engineering thermoplastic or machined metal
- Six pressure-boundary feed-thru layouts with accommodation for 1 – 6 cables
- Split-shell jam nut versions with EMI/RFI shield termination porch
- O-ring sealed panel and box mounting interface
- Conductive and non-conductive finish options

WIRE PROTECTION

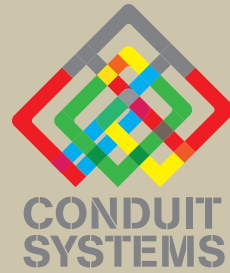

US Navy Qualified Helical Metal-Core Conduit for Above- and Below-Deck Shipboard Wire Routing Applications

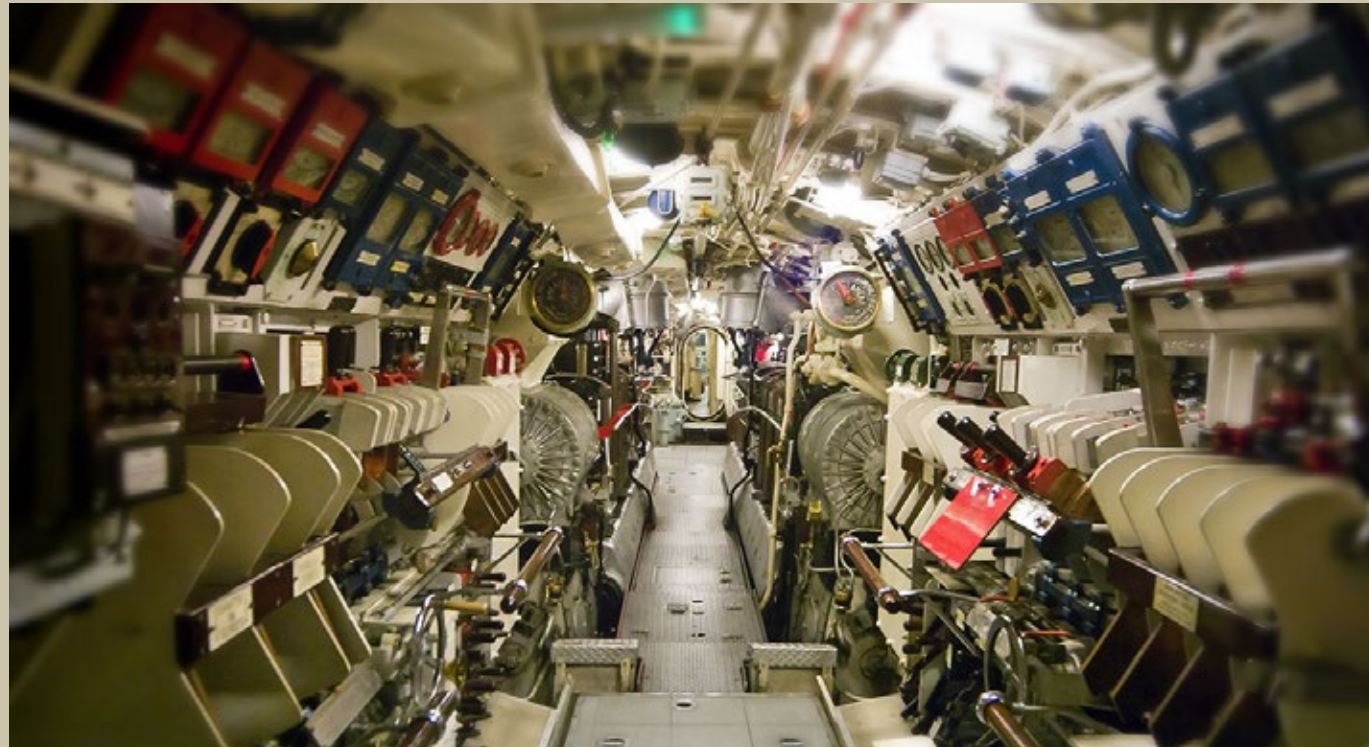

Improved sealing and shielding: the ultimate in highly flexible, crush-proof EMI/EMP wire protection

- Hermetically sealed, flexible metal-core conduit for shipboard wire interconnect applications
- UV-resistant “BlueJacket” jacketing over Brass, Stainless Steel, or Nickel Iron Alloy conduit
- Turnkey, factory-terminated assemblies for fast-turnaround dockside maintenance cycles
- All materials deliver superior EMC performance as well as crush resistance and environmental sealing compared to legacy systems



Part Number 750-098

Select for superior crush resistance and corrosion protection

Highly flexible crush-proof metal conduit in stainless steel with Viton, Neoprene, or Bluejacket protective covering

Part Number 750-192

Select for low-frequency EMC protection in and around motors and control equipment

Nickel-iron conduit material plus shielding and jacketing

MIL-PRF-24758A NAVSEA-APPROVED Metal-Core Conduit Wire Protection Systems



US Navy Qualified Brass, CRES, and Nickel-Iron, with Glenair Signature “BlueJacket” jacketing

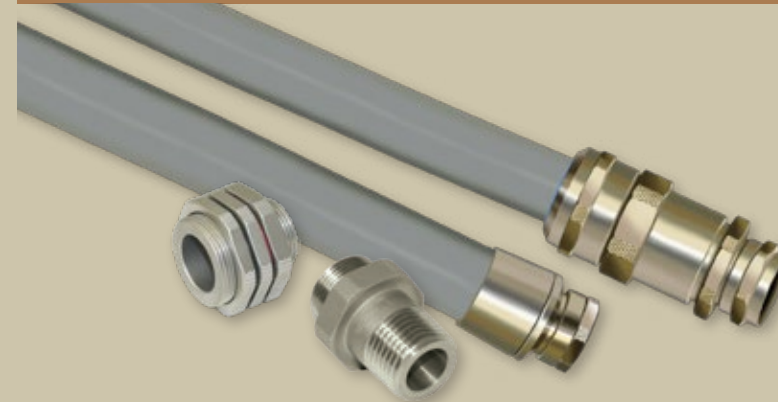

- Qualified to MIL-PRF-24758A(SH)
- User-installable and factory terminated configurations
- Innovative fitting design with advanced environmental sealing, EMI shield termination and rotatable coupling nut
- Adapters for all shipboard interfaces—fully compatible with legacy MIL-C-24758 conduit system components

Do it once, do it right with Glenair Signature MIL-PRF-24758A wire protection conduit systems

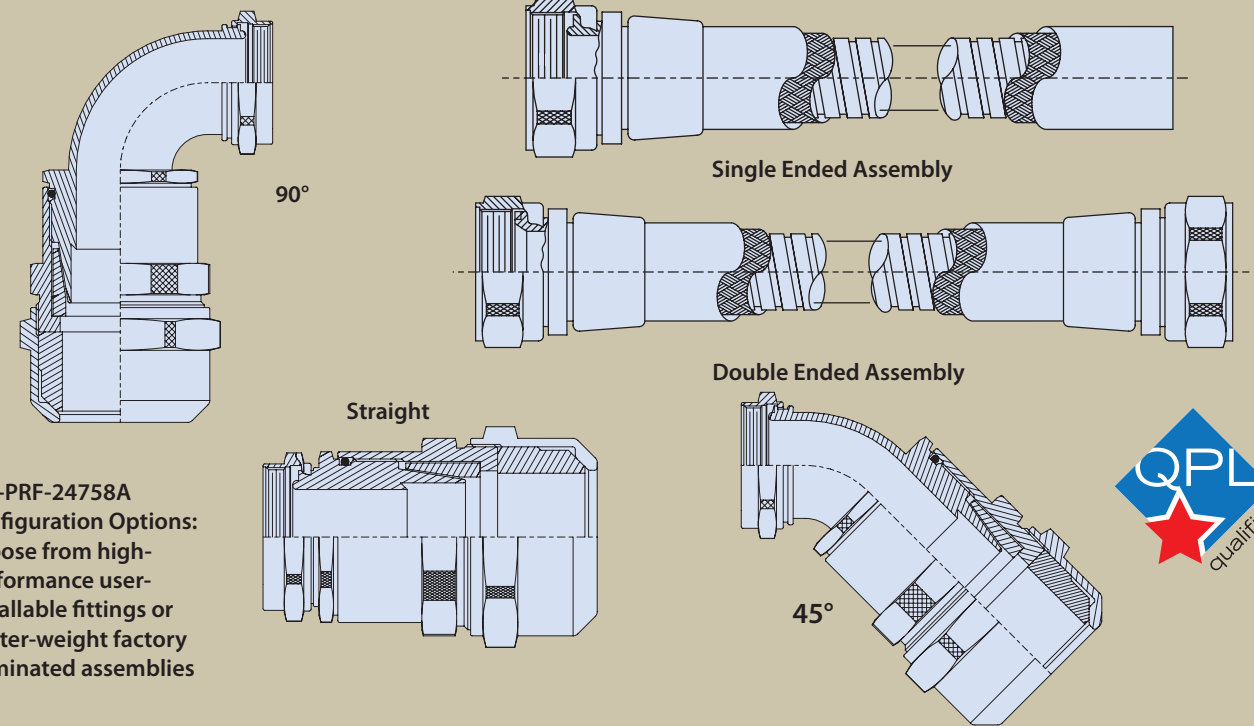

MIL-PRF-24758A Configuration Options: Choose from high-performance user-installable fittings or lighter-weight factory terminated assemblies



FITTINGS AND ADAPTERS FOR USER-INSTALLED APPLICATIONS



WIRE PROTECTION

Piggyback shrink boot feed-thru

Backshells with integrated partially-recovered heat shrink boots for fast, repeatable, reliable installation



Piggyback shrink boot feed-thru

Backshells with integrated partially-recovered heat shrink boots for fast, repeatable, reliable installation



630-101 METAL PIGGYBACK BOOT FEED-THRU



How to Order						
Sample Part Number	630-101	NF	10	A	-2	D
Product Series	630-101 = Metal Feed-Thru					
Finish Symbol	M = Electroless nickel MT = Nickel-PTFE NF = Cad/O.D. over electroless nickel (500 hour salt spray) ZR = Zinc-nickel, black over electroless nickel					
Dash Number	07, 08, 09, 10, 11, 13, 15, 17, 19, 21, 23, 25, 27, 30, 32, 34, 36 (see sales drawing for details)					
Style	A = Feed-thru and shrink boot (one side) B = Feed-thru with shrink boots on both sides					
Boot Material Type	-1 = Type 1 high-performance semi-rigid elastomer -2 = Type 2 zero-hal semi-rigid polyolefin -3 = Type 3 general-purpose flexible polyolefin					
Mounting Hole Type	D = 'D' type mounting hole, available for style A only Omit for none					

630-103 COMPOSITE PIGGYBACK BOOT FEED-THRU



How to Order						
Sample Part Number	630-103	XM	07	A	-2	D
Product Series	630-103 = Composite Feed-Thru					
Finish Symbol	XM = Electroless nickel XW = Cad/O.D. over electroless nickel XZR = Zinc-nickel, black over electroless nickel XMT = Nickel-PTFE					
Dash Number	07, 08, 09, 10, 11, 13, 15, 17, 19, 21, 23, 25, 27, 30, 32, 34, 36 (see sales drawing for details)					
Style	A = Feed-thru and shrink boot (one side) B = Feed-thru with shrink boots on both sides					
Boot Material Type	-1 = Type 1 high-performance semi-rigid elastomer -2 = Type 2 zero-hal semi-rigid polyolefin -3 = Type 3 general-purpose flexible polyolefin					
Mounting Hole Type	D = 'D' type mounting hole, available for style A only Omit for none					

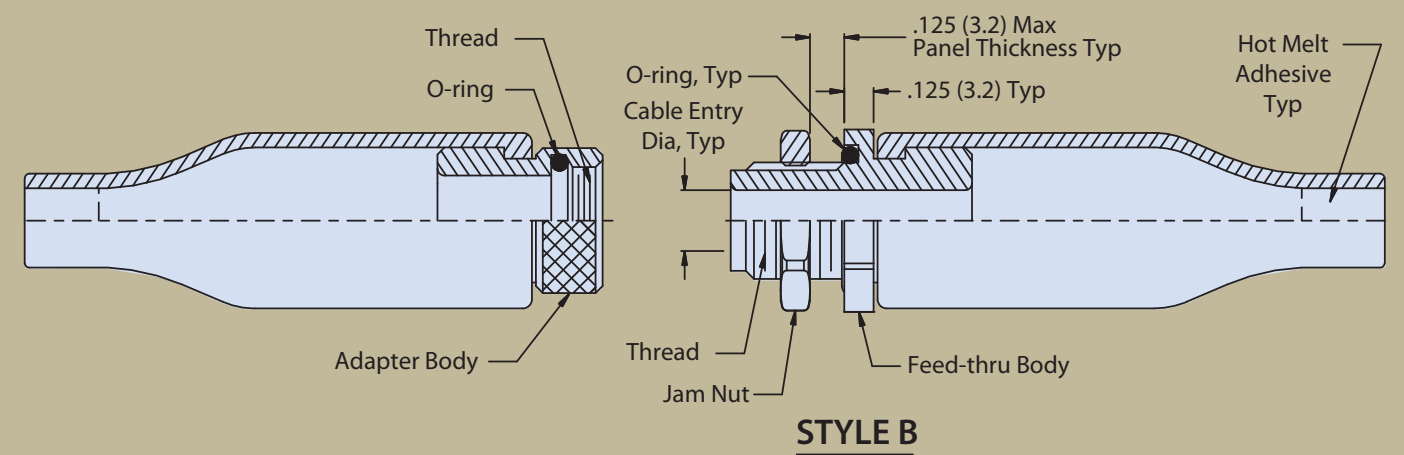
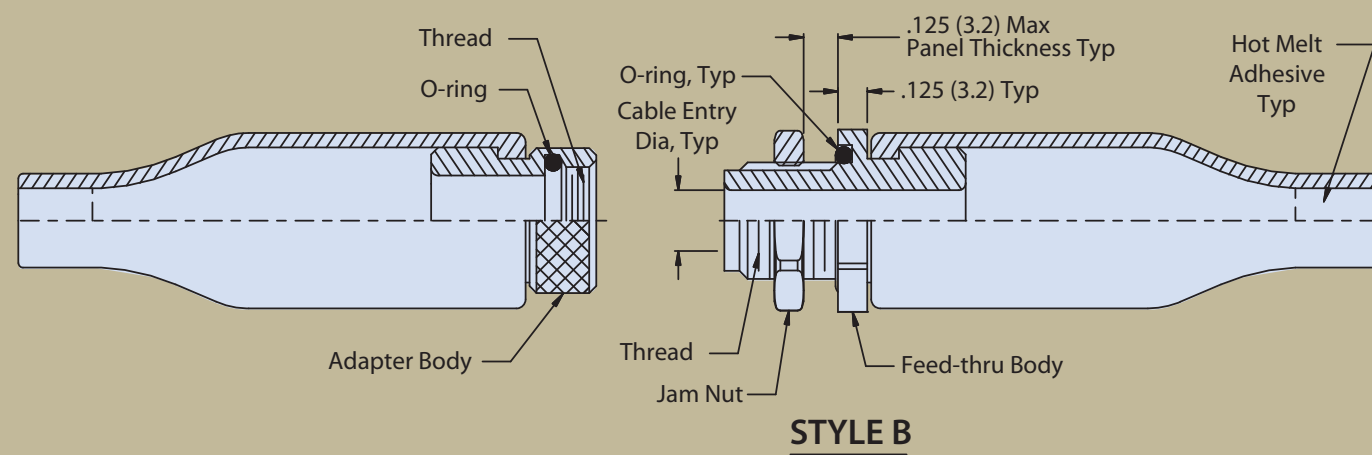
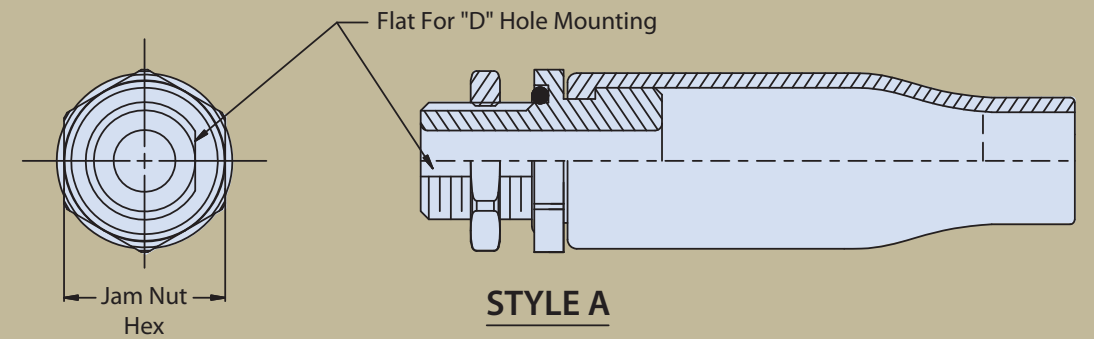
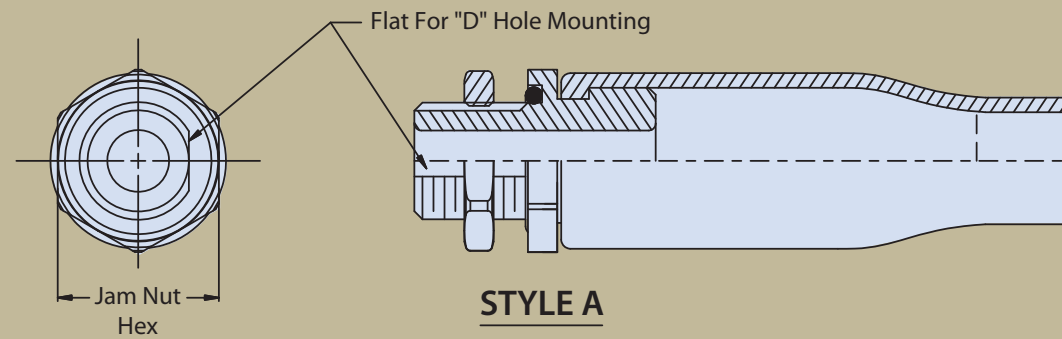

MATERIAL/FINISH

- Feed-thru bodies, adapter and jam nut: aluminum alloy
- O-ring: Silicone/N.A.
- Shrink Boot: Elastomeric/N.A.

MATERIAL/FINISH

- Feed-thru bodies, adapter and jam nut: high-grade engineering thermoplastic
- O-ring: Silicone/N.A.
- Shrink Boot: Elastomeric/N.A.

Piggyback shrink boot adapters

Backshells with integrated partially-recovered heat shrink boots for fast, repeatable, reliable installation



310-057 COMPOSITE PIGGYBACK BOOT ADAPTER FOR MIL-DTL-5015, MIL-DTL-26482, OR MIL-DTL-28840 CONNECTORS



How to Order	
Sample Part Number	310 A S 057 BM 16 -2 K
Product Series	310 = Environmental piggyback boot
Connector Designator	A = MIL-DTL-5015 or MIL-DTL-26482 connectors G = MIL-DTL-28840 connector
Angle	S = Straight A = 90° B = 45°
Basic Number	057
Finish Symbol	BM = Electroless nickel BMT = Nickel-PTFE BNS = Elective plating, nickel and cad O.D. see detail B
Shell Size	08, 10, 12, 14, 16, 18, 20, 22, 24, 28 (5015 / 26482 connectors) 11, 13, 15, 17, 19, 23, 25 (28840 connectors) (see sales drawing for details)
Boot Material	-1 = Type 1 high-performance semi-rigid elastomer -2 = Type 2 zero-hal semi-rigid polyolefin -3 = Type 3 general-purpose flexible polyolefin
Pre-Coiled Band	K = Pre-coiled band Omit for none

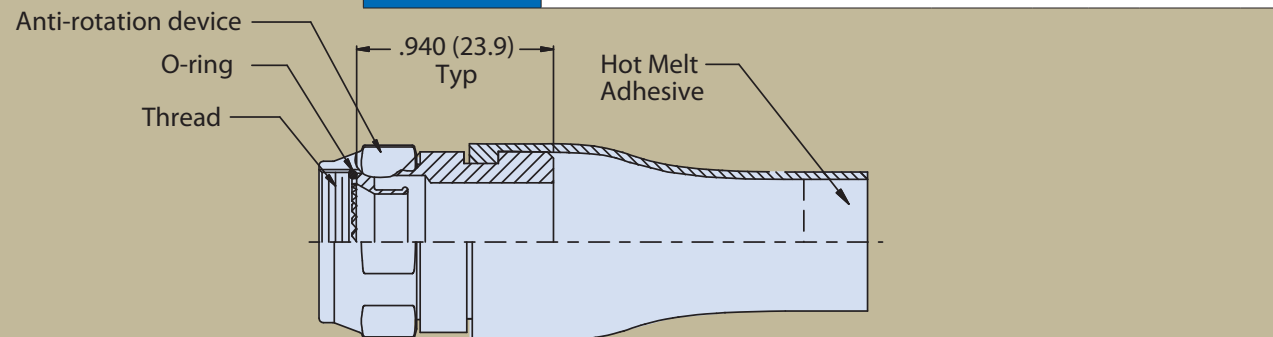

Sym S - Straight

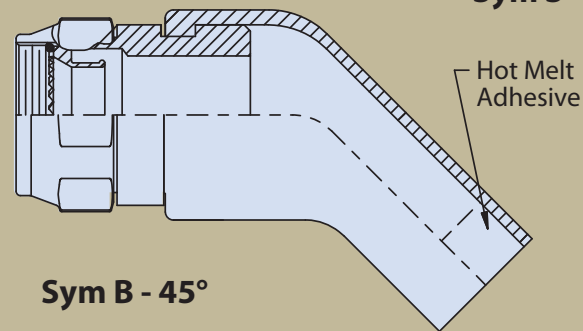

Sym B - 45°

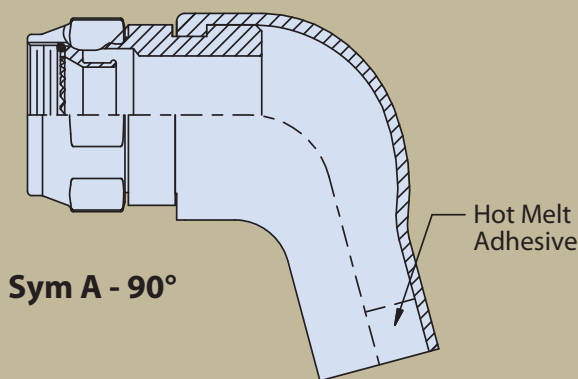

Sym A - 90°

MATERIAL/FINISH

- Coupling nut and adapter: high-grade engineering thermoplastic, black
- Drop-in adapter: brass/electroless nickel • Anti-decoupling device: high-grade engineering thermoplastic • O-ring: silicone/none • Band: SST/passivated

Piggyback shrink boot adapters

Backshells with integrated partially-recovered heat shrink boots for fast, repeatable, reliable installation



319-183 COMPOSITE PIGGYBACK BOOT ADAPTER WITH INTEGRATED SHIELD SOCK FOR MIL-DTL-5015, MIL-DTL-26482, OR MIL-DTL-28840 CONNECTORS



How to Order	
Sample Part Number	319 A S 183 XM 19 B 2
Product Series	319 = Environmental piggyback boot
Connector Designator	A = MIL-DTL-5015 or MIL-DTL-26482 connectors G = MIL-DTL-28840 connector
Angle	S = Straight W = 90° T = 45°
Basic Number	183
Finish Symbol	XM = 2000 hr. corrosion-resistant electroless nickel XMT = 2000 hr. corrosion-resistant nickel-PTFE XW = 2000 hr. corrosion-resistant cad/OD over electroless nickel
Shell Size	08, 10, 12, 14, 16, 18, 20, 22, 24, 28 (5015 / 26482 connectors) 11, 13, 15, 17, 19, 23, 25 (28840 connectors) (see sales drawing for details)
Braid Option	A = 100% AmberStrand® B = 75%/25% AmberStrand® Blend - = Nickel/Copper 34 AWG T = Tin/Copper 34 AWG L = Armorlite™
Boot Material	-1 = Type 1 high-performance semi-rigid elastomer -2 = Type 2 zero-hal semi-rigid polyolefin -3 = Type 3 general-purpose flexible polyolefin

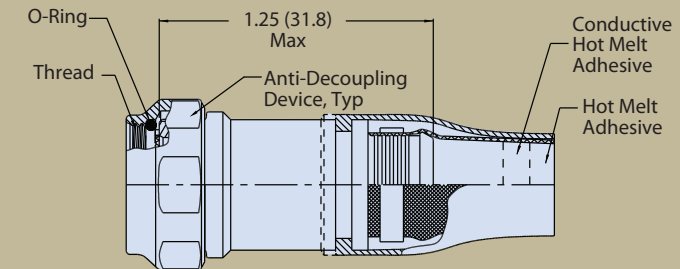

Sym S - Straight

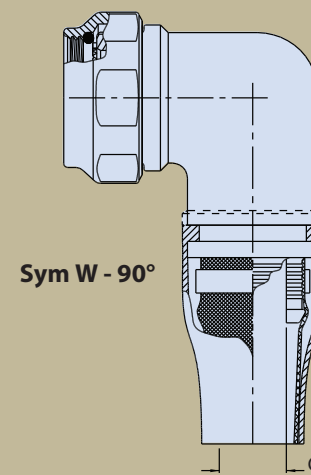

Sym W - 90°

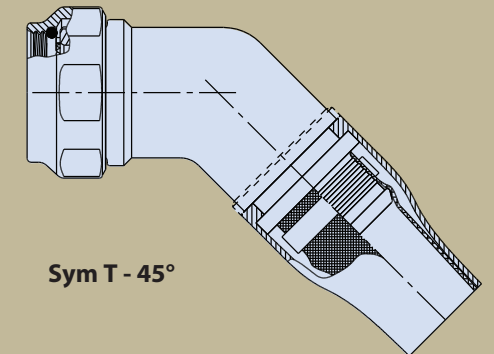

Sym T - 45°

MATERIAL/FINISH

- Elbow, adapter, coupling nut, anti-decoupling device : high-grade engineering thermoplastic
- Drop-in adapter: brass/electroless nickel • O-ring: silicone/none • Band: SST/passivated

Piggyback shrink boot adapters

Backshells with integrated partially-recovered heat shrink boots for fast, repeatable, reliable installation

443-033 COMPOSITE PIGGYBACK BOOT ADAPTER FOR FOR MIL-DTL-5015, MIL-DTL-26482, OR MIL-DTL-28840 CONNECTORS



How to Order	
Sample Part Number	443 A S 033 XM 19 20 K S -2
Product Series	443 = Environmental piggyback boot
Connector Designator	A = MIL-DTL-5015; MIL-DTL-26482 Sr. II G = MIL-DTL-28840
Angular Function	S = Straight W = 90°
Basic Number	033
Finish Symbol	XM = 2000 hr. corrosion-resistant electroless nickel XMT = 2000 hr. corrosion-resistant nickel-PTFE XW = 2000 hr. corrosion-resistant cad/OD over electroless nickel
Shell Size	08, 10, 12, 14, 16, 18, 20, 22, 24, 28 (5015 / 26482 connectors) 11, 13, 15, 17, 19, 23, 25 (28840 connectors) (see sales drawing for details)
Entry Code	10, 12, 14, 16, 18, 20, 22, 24, 28, 32
Band Option	K = Pre-coiled band Omit for none
Slot Option	S = Pigtail slot Omit for none
Boot Material Type	-1 = Type 1 high-performance semi-rigid elastomer -2 = Type 2 zero-hal semi-rigid polyolefin -3 = Type 3 general-purpose flexible polyolefin

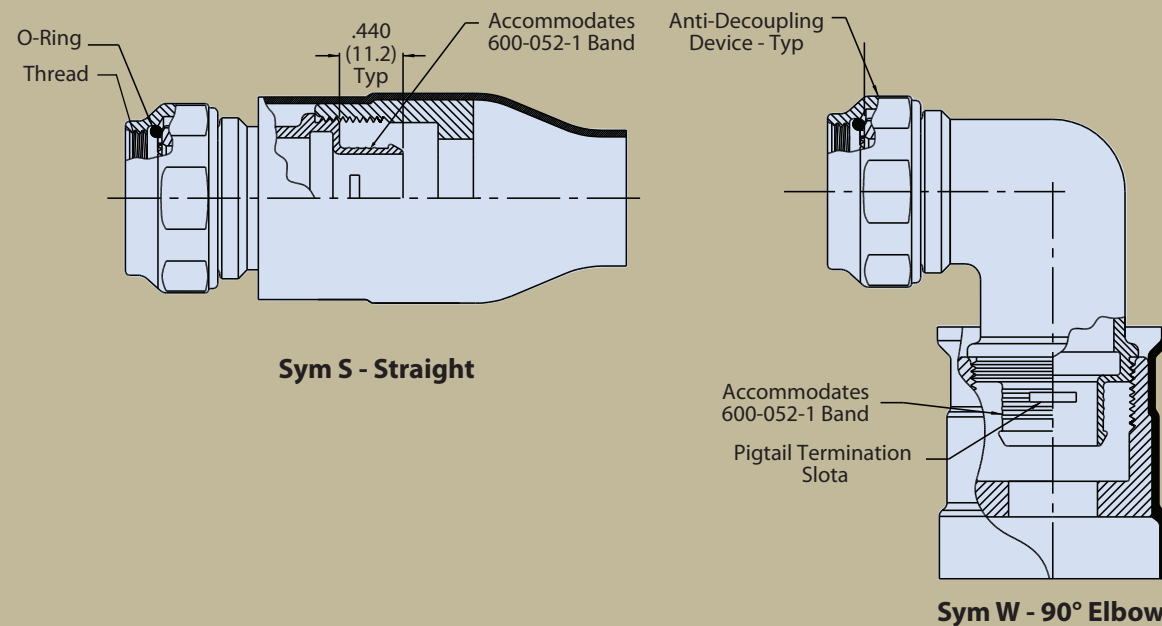

MATERIAL/FINISH

- Elbow, adapter, coupling nut, body clamp, support ring, anti-decoupling device: high-grade engineering thermoplastic
- Hardware: CRES/passivated
- Drop-in adapter: brass/electroless nickel
- O-ring: silicone/none
- Band: SST/passivated

ProSeal™ environmental connector covers

for MIL-DTL-5015, MS 3100, and MS3400 connectors
Threaded closure seal, full environmental



667-450 PROSEAL PROTECTIVE COVER FOR MIL-DTL-5015, MS3100, AND MS3400 CONNECTORS

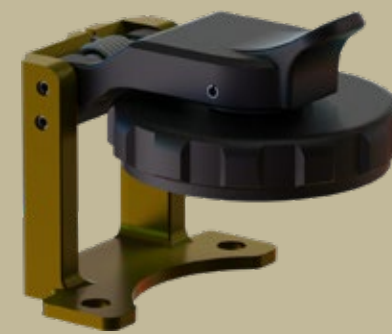

How to Order 667-450	
Sample Part Number	667-450 NF 06 T1 W
Series	ProSeal protective cover for MIL-DTL-5015, MS3100, and MS3400
Finish	MT = Nickel-PTFE ZR = Zinc-Nickel, Black (Tri-Valent CR) M = Electroless Nickel NF = Cad / OD over Electroless Nickel C = Anodize / Black UC = Zinc Cobalt / Black
Shell Size	01, 02, 03, 04, 05, 06, 07, 08, 09, 10, 11, 12, 13, 14, 15, 16
Panel Thickness	T0 = .000" panel T1 = .062" (1.57mm) panel T2 = .125" (3.18mm) panel
Type of Mounting	J = Jam Nut Mount Receptacle W = Wall Mount Receptacle

- Threaded closure
- Full environmental protection
- Self-aligning
- Positive spring-action in closed position. Locks open at approximately 105° from receptacle face.

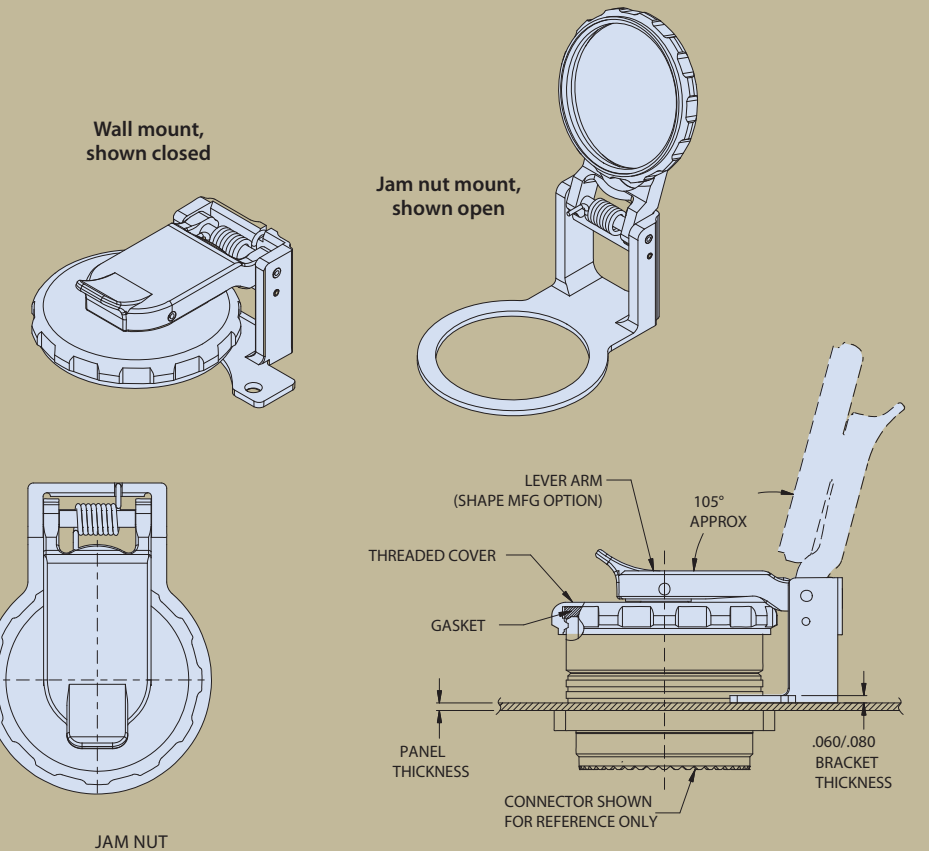

MATERIAL / FINISH

- Cover, Lever Arm, Gimbal - Thermoplastic / Black
- Bracket - Aluminum
- Spring / Pin / Rivet - 300 Series SST / Passivate
- Sleeve - Delrin
- Gasket - Silicone (optional)

WIRE PROTECTION

WIRE PROTECTION

SPRING ACTION

ProSeal™ environmental connector covers

for MIL-DTL-5015, MS 3100, and MS3400 connectors
Pressure seal, dust and immersion resistant

SPRING ACTION

ProSeal™ environmental connector covers

for MIL-DTL-26482 Series I and II connectors
Pressure seal, dust and immersion resistant



667-451 PROSEAL PROTECTIVE COVER FOR MIL-DTL-5015, MS3100, AND MS3400 CONNECTORS

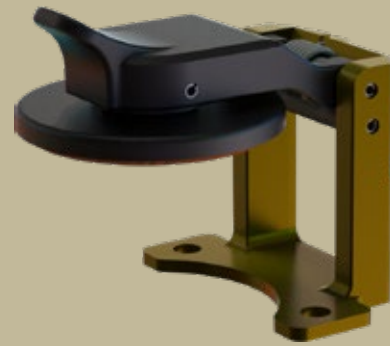

How to Order 667-451					
Sample Part Number	667-451	NF	06	T1	W
Series	ProSeal protective cover for MIL-DTL-5015, MS3100, and MS3400				
Finish	MT = Nickel-PTFE ZR = Zinc-Nickel, Black (Tri-Valent CR) M = Electroless Nickel NF = Cad / OD over Electroless Nickel C = Anodize / Black UC = Zinc Cobalt / Black				
Shell Size	01, 02, 03, 04, 05, 06, 07, 08, 09, 10, 11, 12, 13, 14, 15, 16				
Panel Thickness	T0 = .000" panel T1 = .062" (1.57mm) panel T2 = .125" (3.18mm) panel				
Type of Mounting	J = Jam Nut Mount Receptacle W = Wall Mount Receptacle				

- Pressure seal, dust and immersion resistant
- Self-aligning
- Positive spring-action in closed position. Locks open at approximately 105° from receptacle face.

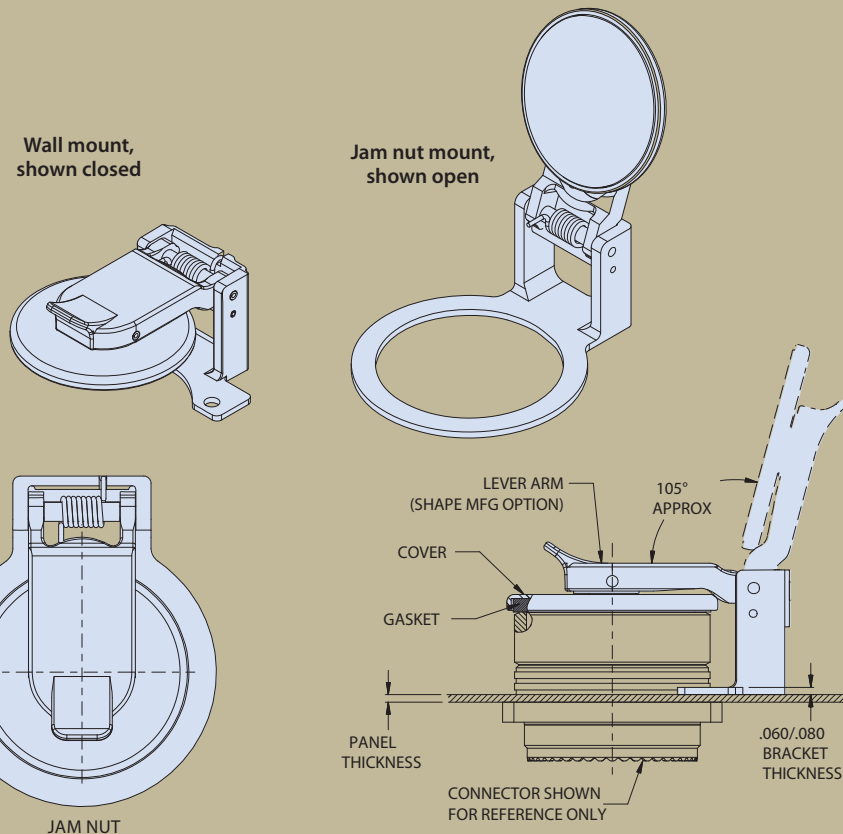

MATERIAL / FINISH

Cover, Lever Arm, Gimbal - Thermoplastic / Black
 Bracket - Aluminum
 Spring / Pin / Rivet - SST / Passivate
 Sleeve - Delrin
 Gasket - Silicone (optional)

667-472 PROSEAL PROTECTIVE COVER FOR MIL-DTL-26482 SERIES I AND II CONNECTORS

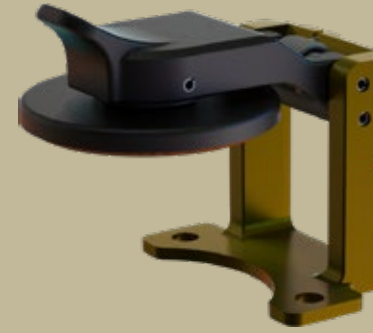

How to Order 667-472					
Sample Part Number	667-472	NF	16	T1	W
Series	ProSeal protective cover for MIL-DTL-26482 Series I and II connectors				
Finish	MT = Nickel-PTFE ZR = Zinc-Nickel, Black (Tri-Valent CR) M = Electroless Nickel NF = Cad / OD over Electroless Nickel C = Anodize / Black UC = Zinc Cobalt / Black				
Shell Size	08, 10, 12, 14, 16, 18, 20, 22, 24				
Panel Thickness	T0 = .000" panel T1 = .031" (.78mm) or 062" (1.57mm) panel T2 = .125" (3.18mm) panel (see sales drawing for details)				
Type of Mounting	J = Jam Nut Mount Receptacle W = Wall Mount Receptacle				

- Pressure seal, dust and immersion resistant
- Self-aligning
- Positive spring-action in closed position. Locks open at approximately 105° from receptacle face.

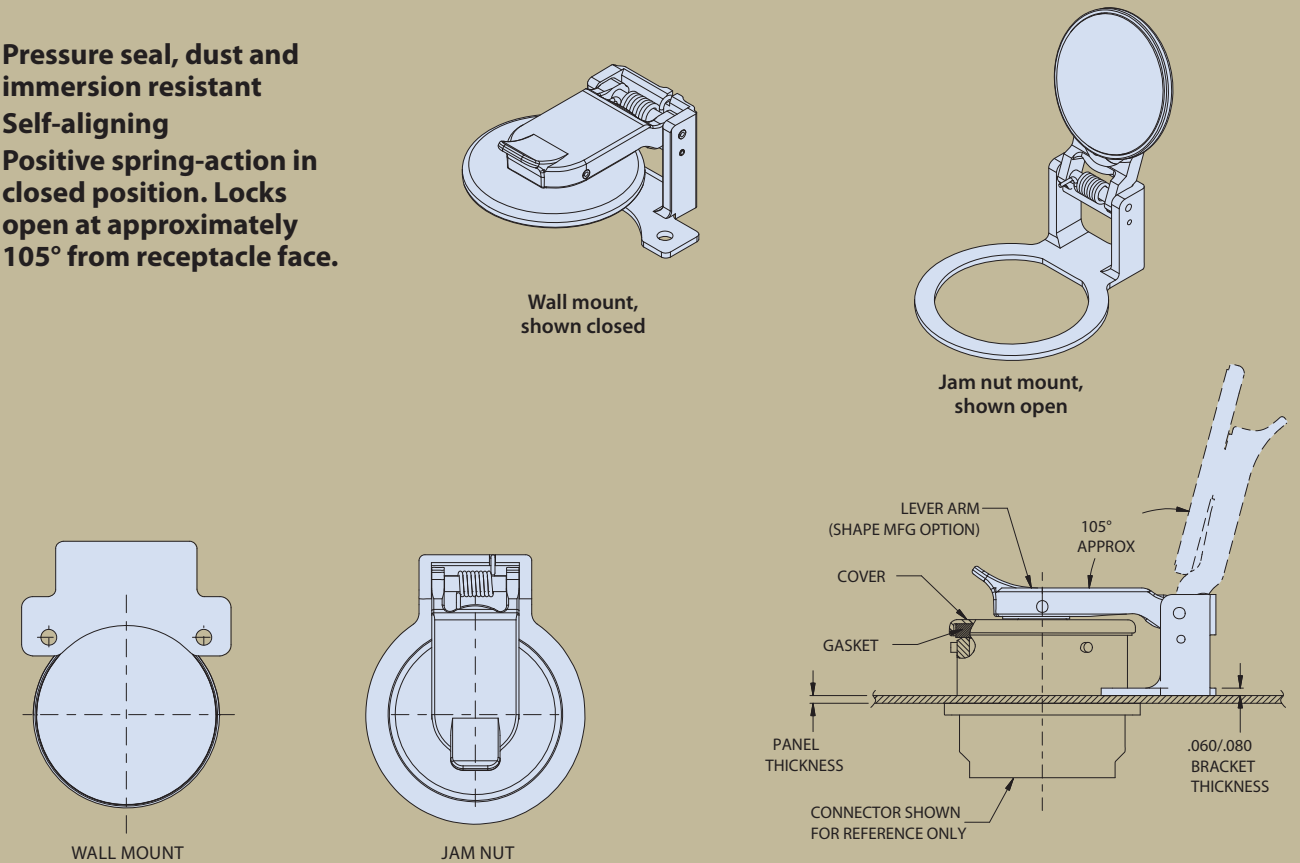

MATERIAL / FINISH

Cover, Lever Arm, Gimbal - Thermoplastic / Black
 Bracket - see Table II
 Spring / Pin / Rivet - 300 Series SST / Passivate
 Sleeve - Delrin
 Gasket - Silicone (optional)

Glenair Mil-Spec Interconnect Technologies



Qualified Products: Glenair is a Mil-Aero connector supplier. Our product quality begins in engineering (the largest team in the high-performance interconnect business) and is realized in our “made in the USA” vertically-integrated manufacturing cells. One of the key ways we ensure both areas are functioning smoothly is to submit designs and manufactured specimens into the military QPL process administered by the Defense Logistic Agency of the US government. These certification exercises are multi-year activities that test every aspect of a connector’s performance.



MIL-DTL-38999 Series III environmental connectors



MIL-DTL-38999 Series IV environmental connectors



MIL-DTL-28840 shipboard connectors and accessories



MIL-DTL-38999 Series I, II, III, and IV hermetic connectors



MIL-DTL-24308 hermetic connectors

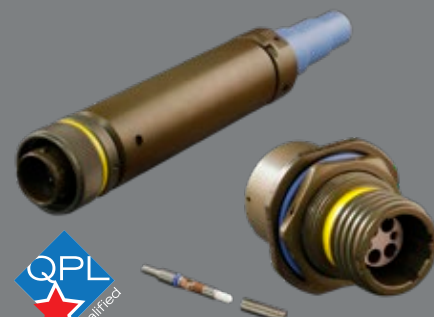

MIL-DTL-28876 shipboard fiber optic

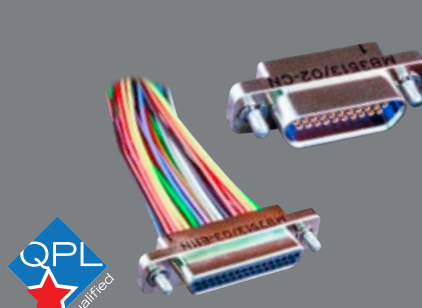

MIL-DTL-83513 Micro-D connectors and accessories

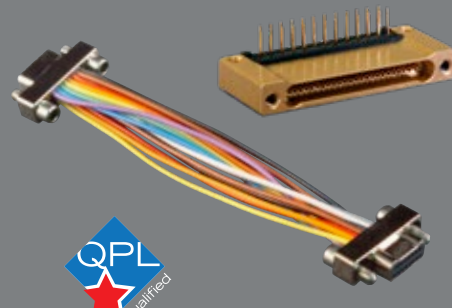

MIL-DTL-32139 Nanominiature connectors and accessories



MIL-DTL-29504 (fiber optic) and AS39029 (electrical) contacts



MIL-DTL-55116 Radio / Audio Connectors



VG95234 Reverse-Bayonet and VG96929 Single-Pole



VG95328 Bayonet-Lock IAW MIL-C-26482



M85049 (AS85049) backshells and connector accessories



MIL-DTL-83723 backshells and connector accessories



M81511 (AS81511) protective covers and connector accessories



M85049/140 series qualified / TACOM-approved environmental shrink boots

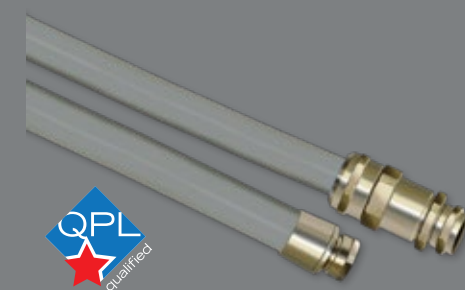

MIL-PRF-24758 Navsea-qualified conduit and fittings



M85049 composite backshells and covers for MIL-DTL-38999

GLENAIR'S COMMITMENT TO QUALITY

Glenair is proud of the quality and reliability we build into our broad range of mission-critical interconnect solutions—from discrete connectors to complex cable assemblies and embedded systems. Glenair is the biggest “made in the USA” interconnect supplier in the high-reliability industry, but we also operate factories in the UK, Italy, and Germany to serve the unique requirements of those markets. Glenair’s Worldwide Quality System is ISO 9001 and AS9100 certified and registered. We also hold many discrete product and operations certifications for specialty, high-performance markets including space, nuclear power, and rail. In addition to world-class quality, we are laser-focused on customer service and committed to being the easiest manufacturer in our industry to do business with. Here are just some of our key customer service principles:



- Lightning-fast turnarounds on quotes and special orders
- Worldwide sales and technical support in every major market
- Full-spectrum, “no gap” product lines
- No dollar or quantity minimums
- ISO 9001 and AS9100 certified
- Huge same-day shipment inventory
- Generous NRE, RMA, and sample request policies
- Abundant engineering and technical support
- No attitudinal constraints when it comes to customer convenience and service



MISSION-CRITICAL INTERCONNECT SOLUTIONS

Glenair, Inc.

1211 Air Way • Glendale, California • 91201-2497

Telephone: 818-247-6000 • Fax: 818-500-9912 • sales@glenair.com

www.glenair.com

Glenair East

20 Sterling Drive
Wallingford, CT
06492

Telephone:
203-741-1115
Facsimile:
203-741-0053
sales@glenair.com

Glenair UK Ltd

40 Lower Oakham Way
Oakham Business Park
Mansfield, Notts
NG18 5BY England

Telephone:
+44-1623-638100
Facsimile:
+44-1623-638111
sales@glenair.co.uk

Glenair Microway Systems

7000 North Lawndale Avenue
Lincolnwood, IL
60712

Telephone:
847-679-8833
Facsimile:
847-679-8849

Glenair Nordic AB

Gustav III : S Boulevard 42
SE-169 27 Solna
Sweden

Telephone:
+46-8-50550000
sales@glenair.se

Glenair GmbH

Schaberweg 28
61348 Bad Homburg
Germany

Telephone:
06172 / 68 16 0
Facsimile:
06172 / 68 16 90
info@glenair.de

Glenair Iberica

C/ La Vega, 16
45612 Velada
Spain

Telephone:
+34-925-89-29-88
Facsimile:
+34-925-89-29-87
sales@glenair.es

Glenair Italia S.p.A.

Via Del Lavoro, 7
40057 Quarto Inferiore –
Granarolo dell'Emilia
Bologna, Italy

Telephone:
+39-051-782811
Facsimile:
+39-051-782259
info@glenair.it

Glenair France SARL

7, Avenue Parmentier
Immeuble Central Parc #2
31200 Toulouse
France

Telephone:
+33-5-34-40-97-40
Facsimile:
+33-5-61-47-86-10
sales@glenair.fr

Glenair Korea

6-21Tapsil-ro 58beon-gil
Giheung-gu, Yongin-si
Gyeonggi-do
Republic of Korea

Telephone:
+82-31-8068-1090
Facsimile:
+82-31-8068-1092
sales@glenair.kr

© 2020 Glenair, Inc.

Printed in U.S.A.